

KARUK TRIBE HOUSING AUTHORITY

P.O. Box 1159 • 635 Jacobs Way
Happy Camp, CA 96039
Ph: (530) 493-1414 • Fax: (530) 493-1415



1836 Apsuun Street
Yreka, CA 96097
Ph: (530) 842-1644 • Fax: (530) 842-1646

NOTICE TO BIDDERS

Date:	May 5, 2023
General Description:	All necessary materials, labor, equipment, and fees needed to install all gutters and downspouts as required in provided plans and documents for seven (7) homes on Second Avenue, Happy Camp, California.
Contact Information:	Karuk Tribe Housing Authority 635 Jacobs Way, PO Box 1159, Happy Camp, CA 96039 Adia Supahan, (530) 493-1414, Extension 3110, asupahan@karuk.us
Project Manager:	Doug Goodwin (530) 598-3911 dgoodwin2@karuk.us
Project Name:	Second Avenue Gutters
MANDATORY Site Visit:	Pre Bid Site Visit NOT REQUIRED
Bid Submission Criteria:	Hand Submission: 635 Jacobs Way, Happy Camp, CA Mail Delivery: PO Box 1159, Happy Camp, CA 96039 Email: asupahan@karuk.us NO FAXES
Bids Due:	Friday, May 19, 2023 by 5pm

KARUK TRIBE HOUSING AUTHORITY

P.O. Box 1159 • 635 Jacobs Way
Happy Camp, CA 96039
Ph: (530) 493-1414 • Fax: (530) 493-1415



1836 Apsuun Street
Yreka, CA 96097
Ph: (530) 842-1644 • Fax: (530) 842-1646

KARUK TRIBE HOUSING AUTHORITY REQUEST FOR LUMP SUM FIXED QUOTATION

SOLICITATION FOR LUMP SUM FIXED-PRICE QUOTATIONS BASED ON PRICE ONLY (Small Purchases of \$250,000 or less)

Due Date: Friday, May 19, 2023 by 5pm

Mandatory Site Visit: Not Required

More Information: Doug Goodwin, (530) 598-3911, dgoodwin2@karuk.us

1. The Karuk Tribe Housing Authority (KTHA) requests lump sum fixed-price quotations for all necessary materials, labor, equipment, and fees needed to install all gutters and downspouts as required in provided plans and documents for seven (7) homes on Second Avenue, Happy Camp, California as described further in the Scope of Work.
2. KTHA is requesting these quotations under the small purchase procedures. This is a less formal, simplified process which will help us to expedite our selection. Because KTHA is following this process, we will not be able to accept quotations that are more than \$250,000.
3. Quotations are invited from non-Indian as well as Indian-owned economic enterprises or organizations.
4. Quotations may be submitted by email, mail, or hand delivery. All quotations must be submitted to KTHA in writing and can be emailed to asupahan@karuk.us, mailed or hand delivered to PO Box 1159, 635 Jacobs Way, Happy Camp, CA 96039 by Friday, May 19, 2023 by 5pm. NO FAXES will be accepted.
5. The Scope of Work is as set forth on Appendix A attached to this Solicitation. Anyone submitting a quotation for this work may visit the job site(s) to ascertain the nature and location of work and to satisfy itself as to the general and local conditions which can affect the work.
6. **Indian Preference.** Any firm seeking Indian preference in this award must provide evidence that it is not less than 51% Indian owned and controlled. If claiming this preference, please contact us immediately so that we can fax you a pre-qualification statement that you must fill out and return within two days of your receipt. KTHA will then review the statement and determine eligibility for preference. All bids must be accompanied by a TERO Compliance Plan as included in Appendix D.
7. **Award.** The contract will only be awarded to a responsive, responsible individual or firm. The contract will be awarded to a qualified Indian enterprise submitting the lowest responsive quotation if such quotation is within budgeting limits established for this solicitation and is within the limits identified in the KTHA Procurement Policy regarding Indian preference in contracting. If no responsive quotation by a qualified Indian enterprise is within the above-stated limits, then award will be made to the individual or firm with the lowest responsive quotation.
8. All quotations must contain a commitment to provide Indian preference in 1) subcontracting, 2) training, and 3) employment, and must contain a statement describing the methods that will be used to provide such preferences. This statement is part of the submitted quotation. This statement will be evaluated as part of the submitted quotation, and any quotation failing to contain such preference statement or failing to adequately address such preference requirements shall be deemed non-responsive. If you believe it is infeasible to provide Indian preference in subcontracting, training, or employment, you must include in your quotation a certification as to the reasons why.

9. The form of Contract which contains the terms and provisions of the contract agreement between KTHA and the individual or firm selected for this work is available for review upon request. By submitting a quotation, you hereby agree that if selected, you shall deliver to the Authority, within the time later designated by the Authority, a properly executed Contract and to be bound by all terms and conditions set forth therein, including but not limited to assurance of performance, completion dates, prevailing wage rates, warranties, other federal requirements, and other terms and provisions as set forth therein.
10. All quotations must commit to remaining open for at least 45 days.
11. The selected contractor will be responsible for paying all Tribal license fees and taxes, as well as permits that may be required, if any.
12. The successful individual or firm on this solicitation must comply with the Tribe's TERO Ordinance, including any licensing requirements. This includes, but is not limited to, paying a 2% TERO fee on the work to be performed. Tribal minimum wage rates shall apply. For a copy of the TERO Ordinance and more information, the Karuk Tribe TERO Director, should be contacted at (530) 493-1600 ext. 2030.
13. This solicitation does not commit KTHA to award a contract or to pay any costs incurred in the preparation of quotation or the procurements of supplies. KTHA reserves the right to reject any and all quotations or to re-solicit when it is deemed by KTHA to be in its best interest to do so.
14. If there are any questions, please contact **Doug Goodwin, Project Manager (530) 598-3911, dgoodwin2@karuk.us** KTHA will let you know the decision of the award.

APPENDIX A
To Request for Lump Sum Fixed-Price Quotation

SCOPE OF WORK

1. Successful bid shall include all necessary materials, labor, equipment, and fees needed to install all gutters and downspouts as required in provided plans and documents for seven (7) homes on Second Avenue, Happy Camp, California.
2. Bid shall include all gutters on each side of the home (approximately 140lf each home), color to be determined by the owner. Heavy snow loads shall be kept in mind when bracing the gutters, bracing shall be at each tail end. Exact dimensions shall be determined by bidder. Typical gutter detail shall be 5-1/2" x 3" x 6" but may vary.
3. Bid shall include a downspout at each corner of the building with proper water runoff at each end as necessary; this shall include all fittings needed to allow for proper drainage from the gutter to the ground. Bid shall include installation of splash guards.
4. Bidders shall acknowledge that the seven homes have not built and will be erected at separate times. Bidders shall make a site visit prior to installation to determine exact sizes, quantities, and dimensions. Bidders shall be flexible to scheduling, and shall account for such in their bids (ex; multiple trips required).
5. Work shall be in accordance with all local building codes per plans.
6. Selected bidder shall be allowed two weeks for material purchases. All work shall be completed within ten days of notification to proceed, per home as they will be built at separate times.
7. Questions may be directed to Doug Goodwin, Project Manager at (530) 598-3911.
8. No pre-bid site visit is required.
9. Bidder shall have appropriate license, certification, and insurance for the work to be performed.
10. Proposals must be received no later than 5pm on Friday, May 19, 2023 at the Happy Camp KTHA Office located at 635 Jacobs Way, Happy Camp, CA 96039. Proposals may be submitted electronically to asupahan@karuk.us Faxes will NOT be accepted.
11. All bids must include a TERO fee of 2%, and Tribal wage rates (as attached) and Indian preference will apply.

APPENDIX A
To Request for Lump Sum Fixed-Price Quotation

TRIBAL WAGE RATES

KARUK TRIBAL WAGE RATES	
Updated April 2011	
Position:	Rate:
CARPENTER	17.00
CEMENT MASON	16.00
ELECTRICIAN	18.00
LABORER	12.00
PAINTER	13.00
PLUMBER	18.00
ROOFER	14.00
SHEET METAL WORKER	18.00
BRIDGE BUILDER	17.00
PILE DRIVER	23.00
MILLWRIGHT	18.00
LINE CONSTRUCTION	22.00
COMMUNICATION SYS	18.00
HEAVY EQUIP OPERAT	16.00
IRON WORKERS	17.00
PLASTERER	16.00
BRICK TENDER	16.00
LANDSCAPE/GARDEN	12.00
DRYWALL FINISHER	16.00
GLAZIER	14.00
SOFT FLOOR LAYER	15.00
TRUCK DRIVER	13.00
TILE SETTER	15.00
BRICK LAYER	17.00

APPENDIX C
To Request for Lump Sum Fixed-Price Quotation

LUMP SUM FIXED PRICE QUOTATION

ITEM	PRICE
SUBTOTAL:	\$
TERO FEE (2% OF SUBTOTAL):	\$
TOTAL QUOTATION AMOUNT:	\$

Respectfully Submitted by,

Signature: _____

Name/Title: _____

Firm: _____

Address: _____

License Number: _____

Phone Number: _____

APPENDIX D
To Request for Lump Sum Fixed-Price Quotation

**TRIBAL EMPLOYMENT RIGHTS OFFICE
COMPLIANCE PLAN FOR BIDDERS**

Bidder/Employer Name: _____

Mailing Address: _____

City, State and Zip Code: _____

Contact Person: _____ Phone Number: _____

E-mail: _____

Bid Amount: \$ _____ TERO Fee (2%): \$ _____

THIS IS AN AGREEMENT BETWEEN THE KARUK TRIBE'S TRIBAL EMPLOYMENT RIGHTS OFFICE (TERO) AND _____, HEREINAFTER KNOWN AS "EMPLOYER" CONDUCTING COMMERCE AND EMPLOYMENT ACTIVITY WITHIN THE ANCESTRAL TERRITORY OF THE KARUK TRIBE.

- Employer shall provide the completed compliance plan with the submission of bid.
- Upon notification of the award, Employer shall contact the TERO Office within ten (10) days prior to any work to be performed.
- Employer shall contact the TERO Office and Contract/Project Manager immediately, in writing, advising of any contract or sub-contractor changes to obtain approval prior to working on the job site.
- Employer understands and agrees to comply with the requirements and procedures in the selection of contractors, sub-contractors, employees and recruitment of viable Indian applicants in accordance with the Karuk Tribe's Employment Rights Ordinance and the Karuk Tribe's Workforce Protection Act (WPA).

By signing below the Employer certifies the position information is true and correct and there have been no omissions in the completion of the labor force projections. Falsification of the information provided will result in sanctions, penalties, fines and/or debarment with the Karuk Tribe.

Employer Signature

Date

PRE-AWARD LABOR FORCE PROJECTION

Core Crew: Is defined as a member of a business, Contractor or Subcontractor’s crew who is a regular employee and is in a supervisory or other key position such that the employer would face a serious financial loss if that position were filled by a person who had not previously worked for that employer.

All other positions will be filled by the TERO office unless sufficient justification can be made that they are not replaceable for the work that is to be done or unless TERO does not have an individual to refer.

List Core Crew (Full Name):	Job Title/ Years w/Company/Justification:

List Native American Contractors/Sub-contractors to be hired for this Project:

Contractor/Sub-contractor Contact Person, Phone # and E-mail:	Work to be Performed:

List Non-Native Contractor/Sub-contractors to be hired for this Project:

Contractor/Sub-contractor Contact Person, Phone # and E-mail:	Work to be Performed:

Open Positions: Employer agrees to hire 100% of all its open positions/Sub-contractors for this project through the TERO Skills Bank. If Employer is unable to hire 100% then company representatives will need to meet with the TERO Director. Failure to comply with this hiring requirement will result in sanctions and/or penalties.

Job Title/Sub-contractor Needed:	Skills Required:

Number of positions to be filled for this project: _____
 Contact person/info for job referrals: _____
 Date TERO referrals needed: _____ Job start date: _____

<p><u>For Internal Use Only:</u></p> <p>Contract Number #: _____ Project Manager: _____</p> <p>TERO Office Approval _____ Date: _____</p> <p><u>Comments:</u></p>

KARUK TRIBE HOUSING AUTHORITY

TWO BEDROOM HOUSE

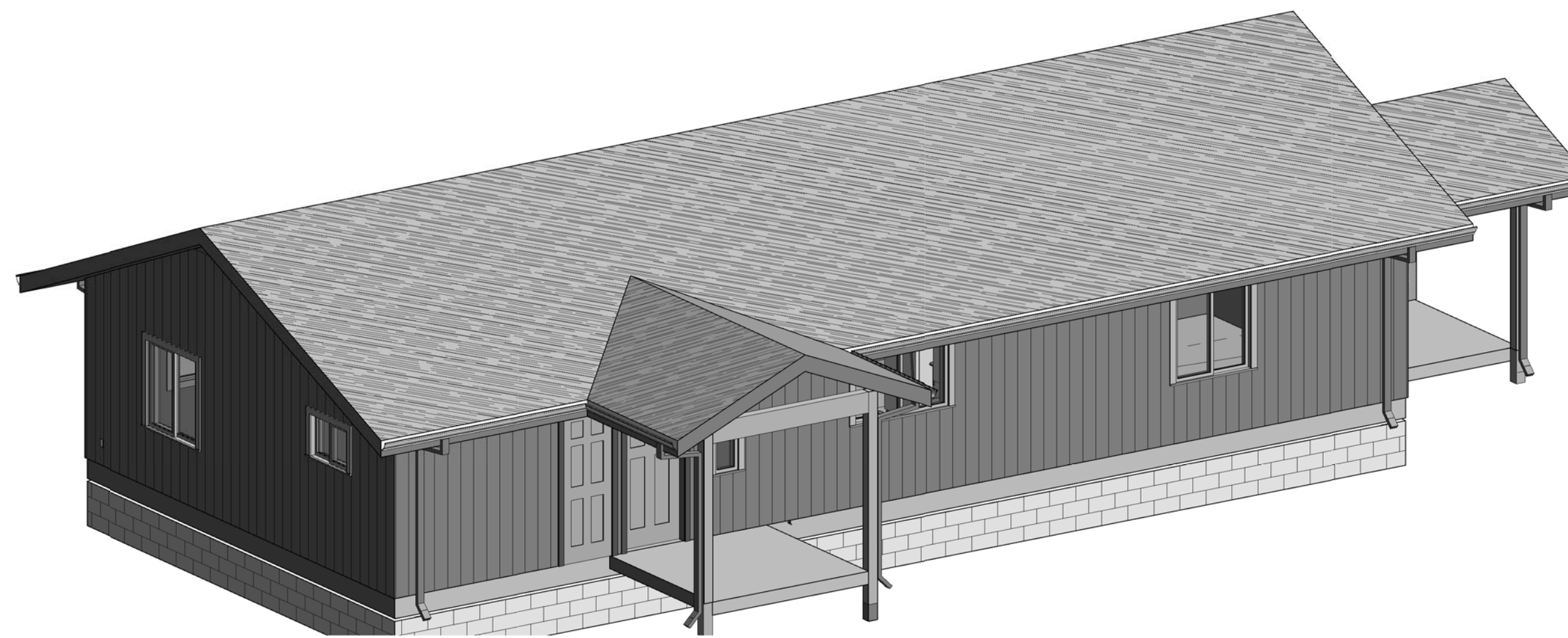

1 Front of Model

ZONING NA
 SITE AREA NA
 TYPE OF CONSTRUCTION V NOT RATED
 OCCUPANCY R-1
 DESCRIPTION OF USE RESIDENCE
 SPRINKLERS YES
 NO. OF STORIES: 1
 BLDG. HEIGHT: 15'±
 FLOOR AREA: 1248 SQ.FT.
 APPLICABLE CODE: CBC 2013(TITLE 24), WHICH ADOPTS THE
 2010 UBC, 2010 UMC, 2010 UPC AND
 2010 NEC

SPECIAL INSPECTIONS:

DEFERRED SUBMITTAL: TRUSS DESIGN
 SPRINKLER DESIGN

Architect:
 J M B Architecture
 P O Box 1170
 WILLOW CREEK, CA. 95573
 Joan Briggs
 530.629.0010

Owner:
 KARUK TRIBE HOUSING AUTHORITY
 PO BOX 1159
 HAPPY CAMP, CA 96039
 Erin Hillman
 Director
 530.598.2124

G-1 TITLE SHEET
 G-2 GENERAL NOTES

STRUCTURAL DRAWINGS
 S1 FOUNDATION PLAN
 S2 FRAMING PLAN

ARCHITECTURAL DRAWINGS
 A1 FLOOR PLAN ROOF PLAN
 A4 EXTERIOR ELEVATIONS
 A5 BUILDING SECTIONS
 A6 DETAILS
 A8 DOOR, WINDOW & FINISH SCHEDULE
 A9 INTERIOR ELEVATIONS

MECHANICAL DRAWINGS
 P1 PLUMBING PLAN
 P2 PLUMBING NOTES & DETAILS
 M1 MECHANICAL PLAN
 E1 POWER & LIGHTING PLAN

STRUCTURAL CRITERIA

BASIC WIND SPEED: 110 MPH
 GROUND SNOW LOAD: 60 PSF

SEISMIC:

SITE CLASS: D
 S_s: 1.155
 S₁: 0.520

SEISMIC CATAGORY: D

PROJECT SUMMARY

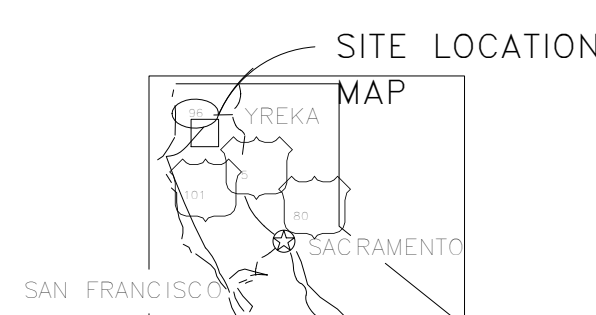

VICINITY MAP

SHEET INDEX

KTHA: _____
 Erin Hillman

JMB Architecture: _____
 Joan Briggs

TVCE: _____
 Josh McKnight

APPROVALS

& ∠ ⊕ ⊖ # (E) ~	And Angle At Centerline Diameter or Round Pound or Number Existing This Sheet	I.D. INSUL. INT. KIT. LAB. LAM. LAV. LT. MAX. M.C. MECH. MEMB. MET. MFR. MH. MIN. MIR. MISC. M.O. MTD. MUL. N. N.I.C. NO. or # NOM. N.T.S.	Inside Diameter (Dim.) Insulation Interior Kitchen Laboratory Laminate Lavatory Light Maximum Medicine Cabinet Mechanical Membrane Metal Manufacturer Manhole Minimum Mirror Miscellaneous Masonry Opening Mounted Mullion North Not in Contract Number Nominal Not To Scale
A.D. ADJ. AL. APPROX. ARCH. ASPH.	Area Drain Adjustable Aluminum Approximate Architectural Asphalt	MEX. M.C. MECH. MEMB. MET. MFR. MH. MIN. MIR. MISC. M.O. MTD. MUL.	Maximum Medicine Cabinet Mechanical Membrane Metal Manufacturer Manhole Minimum Mirror Miscellaneous Masonry Opening Mounted Mullion
BD. BLDG. BLK. BLKG. BM. BOT.	Board Building Block Blocking Beam Bottom	O.A. OBS. O.C. O.D. OFF. OPNG. OPP.	Overall Obscure On Center Outside Diameter (Dim.) Office Opening Opposite
CAB. CEM. CER. C.I. CLG. CLKG. CLO. CLR. C.O. CLM. CONC. CONN. CONSTR. CONT. CTS.K. CNTR. CTR.	Cabinet Cement Ceramic Cast Iron Ceiling Caulking Closet Clear Cased Opening Column Concrete Connection Construction Continuous Countersunk Counter Center	PRC ST. PL. P.LAM. PLAS. PLYWD. PR. PT. PTN.	Pre-cast Plate Plastic Laminate Plaster Plywood Pair Point Partition
DBL. DEPT. DET. DIA. DIM. DN. D.O. DR. DWR. DS. DWGS.	Double Department Detail Diameter Dimension Down Door Opening Door Drawer Downspout Drawings	Q.T.	Quarry Tile
E. EA. E.J. EL. ELEC. EMER. ENCL. E.P. EQ. EQPT. EXIST. EXPO. EXT.	East Each Expansion Joint Elevation Electrical Emergency Enclosure Electrical Panelboard Equal Equipment Existing Exposed Exterior	R. RAD. R.D. REF. REFR. REINF. REQ. RM. R.O. RWD.	Riser Radius Roof Drain Reference Refrigerator Reinforced Required Room Rough Opening Redwood
F.A. F.D. FDN. F.E. FIN. FL. FLASH. FLUOR. F.O.C. F.O.F. F.O.S. FPRF. F.S. FT. FTG. FURR. FUT.	Fire Alarm Floor Drain Foundation Fire Extinguisher Finish Floor Flashing Fluorescent Face of Concrete Face of Finish Face of Studs Fireproof Full Size Foot or Feet Footing Furring Future	S. S.C. SCHD. SECT. SH. SHR. SHT. SIM. SPEC. SQ. S.ST. STD. STL. STOR. STRUCT. SYM.	South Solid Core Schedule Section Shelf Shower Sheet Similar Specification Square Stainless Steel Standard Steel Storage Structural Symmetrical
G.A. GALV. G.B. GL. GND. GR. GYP.	Gauge Galvanized Grab Bar Glass Ground Grade Gypsum	TRD. T.C. TEL. TER. T.&G. THK. T.P. T.V. T.W. TYP.	Tread Top of Curb Telephone Terrazzo Tongue and Groove Thick Top of Pavement Television Top of Wall Typical
H.B. H.C. HDWD. HDWE. H.M. HORIZ. HR. HGT.	Hose Bibb Hollow Core Hardwood Hardware Hollow Metal Horizontal Hour Height	UNF. U.O.N. VERT. W. W/ W.C. WD. W/O WP.	Unfinished Unless Otherwise Noted Vertical West With Water Closet Wood Without Waterproof

TYPICAL ABBREVIATIONS

(A) 1	COLUMN LINE LETTERS IN ONE DIRECTION NUMBERS IN THE OTHER DIRECTION
101A	DOOR SYMBOL DOOR NUMBER
4	WINDOW TYPE SKIP LETTERS "I" AND "O"
◇	LOUVER TYPE
⬢	EQUIPMENT TYPE TYPE OF EQUIPMENT, X=X-RAY; F=FOOD SERVICE EQUIPMENT GROUP
☁	REVISION CLOUD AROUND REVISION
◐	MATCH LINE SHADED PORTION IS THE SIDE CONSIDERED
⊕	WORK POINT, CONTROL POINT OR DATUM POINT
1 A2.1	SECTION SECTION IDENTIFICATION SHEET WHERE SECTION IS DRAWN
5 A9.1	DETAIL DETAIL IDENTIFICATION SHEET WHERE DETAIL IS DRAWN
⊕	INTERIOR ELEVATION(S) ELEVATION NO. ELEVATION IDENTIFICATION (NO ARROWS MEANS ELEVATION NOT SHOWN) SHEET WHERE ELEVATION IS DRAWN
OFFICE 101	ROOM IDENTIFICATION ROOM NAME ROOM NO.
77.0	NEW FINISH GRADE DRAWN @ 45°
68.5	EXISTING GRADE SHOWN HORIZONTALLY
—	PROPERTY LINE
78	NEW OR FINISHED CONTOURS
71	EXISTING CONTOURS
T.W. 15.0	TOP OF WALL
T.C. 15.0	TOP OF CURB
T.P. 15.4	TOP OF PAVEMENT
▨	ACOUSTIC TILE OR BOARD
▨	BITUMINOUS CONCRETE SHOW PROFILE ONLY
▨	BRICK
▨	CERAMIC TILE SHOW PROFILE ONLY
▨	CONCRETE CAST IN PLACE OR PRECAST
▨	CONCRETE BLOCK
▨	EARTH
▨	GLASS OMIT INDICATION IN THIN MATERIAL
▨	GYPSUM BOARD OMIT DOUBLE LINES AT SMALL SCALE
▨	INSULATION, BATT
▨	INSULATION, RIGID
▨	METAL OMIT INDICATION IN THIN MATERIAL
▨	METAL LATH
▨	MORTAR
▨	PLASTER
▨	PLYWOOD
▨	ROCK FILL
▨	SAND
▨	STONE INCLUDES MARBLE
▨	TERRAZZO SHOW PROFILE ONLY
▨	WOOD, FINISH
▨	WOOD, FRAMING THROUGH MEMBER
▨	WOOD, FRAMING INTERRUPTED MEMBER
▨	REMOVE OR DEMOLISH

TYPICAL SYMBOLS

JMB
 ARCHITECTURE
 ARCHITECTURE
 PLANNING

4767 HIGHWAY 96 PO BOX 1170
 WILLOW CREEK, CA 95573
 707.629.0010 fax 707.629.2348
 email: jmbarchitect@snowcrest.net

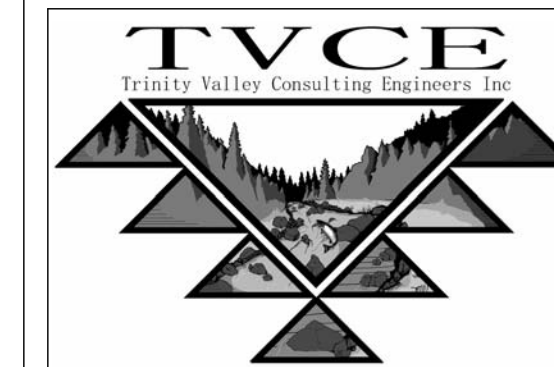

67 Walnut Way PO BOX 1567
 WILLOW CREEK, CA 95573
 707.629.3000 fax 707.629.3011
 email: tvce@tvce.biz

Electrical
 Consultant
 Pace Engineering
 1730 South Street
 Redding, CA
 96001
 530 244-0202
 530 244

Bldg. Energy
 Consultant
 Address
 Phone
 Fax
 e-mail
 Abby Technical Services
 Anny McQuerry
 1125 16th Street, Ste. 216
 Arcata, CA 95521
 707-826-1433
 707-826-1430
 anny@
 abbytechnicalservices.com

KARUK TRIBE
 HOUSING AUTHORITY
 Two Bedroom House

No.	Description	Date

Title Sheet

Project number	ktha 2015
Date	07/05/2015
Drawn by	RKH
Checked by	JMB

G1

Scale

GENERAL

1. DO NOT SCALE DRAWINGS
2. The drawings and specifications, and copies thereof are legal instruments of services for use by the owner and authorized representatives on the designated property only.
3. All work shall be executed in accordance with the 2010 edition of the California Building Code and/or all other governing agencies requirements.
4. Contractor shall comply with the regulations of "Occupational Safety and Health Act."
5. All dimensions and conditions shall be checked and verified on the job site by the contractor before work begins. Any errors, omissions, or discrepancies shall be brought to the attention of the architect and owner before construction begins.
6. In the event there are found discrepancies or ambiguities in or omissions from the specifications or the drawings, or should there be doubt as to their meaning or intent, the Architect shall be notified, and shall provide a written clarification prior to the commencement of construction or the purchasing of the materials. Failure on the part of the Contractor to follow this procedure shall relieve both the Architect and the owner of damages, costs, and time delays created by these conditions.
7. Contractor shall examine the condition of the project area and verify the sizes and locations of existing facilities at the site, report any discrepancies between the drawings and existing conditions to the owner and the architect, and shall not commence until the conditions are further clarified or authorization to proceed is given.
8. Dimensions shown on the drawings are to centerline of column or face of stud, unless otherwise noted.
9. Work shall conform to all local, state, and federal codes and ordinances in effect and all safety provisions shall be strictly adhered to.
10. There will be no substitutions without the Owner's written prior approval.
11. The Architect makes no guarantee for products identified by trade name or manufacturer, nor their availability; however, the Contractor shall be responsible for meeting the performance requirement of the specification.
12. Contractor shall be responsible for and obtain all permits and licenses and pay required fees. Certificates of insurance for Workers Compensation shall be filed prior to issuing of permit.
13. Each Contractor shall guarantee, be responsible for and make good any and all defects due to faults of his/her trade for labor, leaks or materials, for a period of one year minimum following the acceptance of the work by the Owner
14. All damages to, both on and off property (alleys, sidewalks, curbs, streets, etc.) occurring as a result of construction shall be replaced or repaired by the Contractor at no cost to the Owner.
15. No materials or refuse shall be kept outside work area. Provide area for combustible rubbish storage.
16. Typical details shall apply where no specific details or sections are given.
17. The Contractor shall be responsible for continuous clean-up of the site and of all debris.
18. Abbreviations throughout the plans are those in common usage. Architect will define intent of any in question.
19. Provide and maintain Fire Extinguishers as required by the Local fire department field inspector during construction.
20. This project shall comply with title 24 and 2013 UBC, UMC and UPC and 2010 HEC.

SITE WORK

1. All site work shall comply with any applicable approved drawings or local codes as required.
2. Soils Report not required.
3. All excess materials shall be disposed of at the Contractor's expense.
4. All concrete curbs and sidewalks shall be installed per the California Department of Transportation Standard Specifications-July 2010, Section 73

EARTHWORK

1. All grading and earthwork shall be executed in accordance with those ordinances of the governing agencies
2. Carry all footings into solid natural or compacted soil a minimum of 12" regardless of elevations shown on the drawings.
3. All fill material shall be compacted to a minimum 95% relative compaction per Cal 216.

CONCRETE

1. The labor, materials and execution required for all concrete work as indicated on the drawings shall be in accordance with those applicable sections of chapter 19 of the latest adopted editions of the uniform building code.
2. All concrete shall be a 5 sack mix and have a minimum compressive strength of 2500 psi at 28 days.
3. Reinforcing steel as required shall be properly anchored and tied in place before pouring concrete. Lap all splices a minimum of 32 bar diameters. Reinforcing steel shall be deformed bars conforming to ASTM designation A-615, Grade 40.

MASONRY

1. The labor, materials and execution required for all masonry work as indicated on the drawings shall be in accordance with those applicable sections of chapter 21 of the latest adopted editions of the uniform building code.

METALS

1. Use approved metal connectors, joist and rafter hangers, post base and cap connectors as required on plans, by code and Building Inspector.
2. All fasteners and hardware in contact with pressure treated lumber shall be hot-dipped galvanized or stainless steel

STEEL

1. The labor, materials and execution required for all structural steel work as indicated on the drawings shall be in accordance with those applicable sections of Chapter 22 of the latest adopted edition of the Uniform Building Code.
2. Structural steel shall conform to the latest specifications of the A.S.T.M. and have a min. yield of 36,000 PSI
3. Bolted or welded connections shall conform to A.I.S.C. specifications unless noted otherwise on the drawings.
4. Structural steel not encased in concrete shall be shop painted with one coat of zinc chromate

WOOD

1. All lumber shall be grade marked #2 DF minimum except as noted on plans.
2. All posts to be #1 DF.
3. All horizontal lumber shall be #1 DF or better.
4. All studs shall be DF standard.
5. Plywood shall be DF conforming to PSI-74 U. S. Dept of Commerce, and shall be grade stamped "D.F.P.A."
6. Wood bearing directly on concrete shall be pressure treated Doug. Fir or Redwood

CARPENTRY

1. All framing and carpentry shall be done in accordance with those applicable sections of Chapter 23 of the latest adopted edition of the Uniform Building Code and details indicated on the drawings.
2. Nailing as per C.B.C. Table 25-Q
3. Structural Members shall not be cut for pipe, conduit or etc.
4. 2 inch solid blocking shall be placed between joists or rafters at all supports
5. Use approved metal connectors, joist and rafter hangers, post base and cap connectors as required on plans, by code and Building Inspector.

MILLWORK

1. All Millwork shall be manufactured in accordance with the standards in the latest edition of Chapter 23 of the Manual of Millwork of the Wood Working Institute in the Custom Grade hereinafter specified or as shown on the drawings
2. Submit Shop Drawings in conformance to Section 1 "Guidelines for Architectural Millwork Shop Drawings".
3. Millwork and installation shall be in accordance with Custom Grade of the Manual of Millwork latest edition
4. Deliver all materials only when project is ready for installation and the General Contractor has provided a clean storage area as defined in the Manual of Millwork

SHEET METAL

1. All sheet metal work shall be in accordance with the latest addition of the "Architectural Sheet Metal Manual" of the Sheet Metal and Air Conditioning Contractors National Association, Inc. SMACNA
2. Flashings, gutters and other galvanized iron (G.I.) shall be 26 gage minimum unless noted otherwise, galvanized hot dip process.

THERMAL & MOISTURE PROTECTION

1. Where penetrations are made through the roof, provide watertight assembly

ROOFING

1. Asphalt composition shingles to be installed per mfr. recommendations. Manufactured by Malarkey Lifetime Warranty Comp. Arch. Shingle, or equal, Color selected by Owner Or Metal Roof FABRAL SSR 1-1/2" or equal, Color selected by Owner
2. All roofing and flashing materials shall be installed in strict conformance with the manufacturer's specification and in accordance with Chapter 15 of the latest adopted edition of the Uniform Building Code.
3. All roof and flashing materials shall be installed to form a waterproof system and the roofing contractor shall issue a written guarantee to the Owner to maintain the roofing and all flashings in a watertight condition for a period of two (2) years after acceptance of the project.

INSULATION

1. Wall insulation R-13 and R-19
2. Ceiling insulation R-30
3. All insulation shall comply with standards established by the State of California "Energy Design Manual" and Energy Regulations of California Administrative Code, Title 25

WEATHER STRIPPING

1. Comply with title 24 requirements for weather stripping at all openings

DOORS & WINDOWS

1. See Sheet A-7
2. Vinyl Low E Double paned Windows and Sliding Glass Doors manufacturer selected by KTHA
3. Exterior Doors 6 Panel Metal Doors with standard Kwikset locks and deadbolts
4. Interior Doors 6 Panel HC with Kwikset hardware

GLAZING

1. All labor, materials and execution required for the glass and glazing work as indicated on the drawings shall be in accordance with those applicable sections of Chapter 24 of the latest adopted edition of the Uniform Building Code.
2. Glass doors, adjacent panels, glazing within 24" of a door, and all glazed openings within 1'-6" of the adjacent floor shall be of tempered glass as approved for impact hazard.
3. All windows shall be certified and labled to meet A.N.S.I. infiltration standards

FINISHES

1. Contractor shall supervise all finish work.
2. Contractor shall provide galvanic insulation between dissimilar metals.
3. All materials and finishes indicated on drawings shall be new, unused, and of serviceable condition except as specifically noted.
4. Wall and Ceiling materials shall not exceed the flame spread classifications in URC table 8-B

EXTERIOR SIDING

1. Siding: LP Siding with 8" grooves
2. Trim: primed spruce 3/4"x4" around windows and doors
3. Soffit: NA

GYPSSUM WALLBOARD

1. The Gypsum Wallboard work shall be done in accordance with the recommendations of ASTM C754,GA 151, GA 201, GA 216 and shall conform with Chapter 25 of the latest adopted edition of the California Building Code
2. Interior walls to be finished with orange peel texture through out

CERAMIC TILE

1. Ceramic tile work shall be in accordance with the best recommended standards of the "Tile Council of America"

PAINTING

1. All painting work, which includes back priming, sealing, staining, lacquering or other work reasonable incidental to the painting of all exterior and interior woodwork, plywood, gypboard, sheet metal, ironwork, etc. shall be in accordance with the recommended standards as set forth in the "Painting Specifications" of the Painting and Decorating Contractors Association of America.
2. Colors of all areas being patched and repaired shall match existing and all new work shall be as directed and per schedule provided by Contractor
3. Paint shall be 100% acrylic, applied per manufacturers recommendations and per schedule provided by Contractor and Owner
4. Interior Walls- prime and paint with two coats semi-gloss latex enamel
Exterior Walls-one coat primer and two coats eggshell finish
Exterior Trim-one coat primer and two coats semi-gloss finish

CARPET

1. Manufactured by NA
2. Color as selected by Owner from manufacturers standards.
3. Install in accordance with manufacturers recommendations.

VINYL

1. Manufactured by Armstrong, Product: NA
2. Color as selected by Owner from manufacturers standards.
3. Install in accordance with manufacturers recommendations.

MECHANICAL

1. See Mechanical Notes sheet M-1

PLUMBING

1. See Plumbing Drawings Sheet P-1, P-2

ELECTRICAL

1. See Electrol Drawing Sheet E-1

ENERGY CONSERVATION

1. All work shall conform to the energy conservation requirements set forth in the California Administrative Code, Title 24.
2. See sheet CF1 and CF2 Energy Statement

SECURITY PROVISIONS

1. All Pin-type hinges which are accessible from outside a secured area when the door is closed shall have non-removable hinge pins. In addition, they shall have minimum 1/4" diameter steel jamb stud with 1/4" minimum protection unless the hinges are shaped to prevent removal of the door if the hinge pins are removed.

FIRE PROTECTION

1. All smoke detectors to be hard wired with battery backup.
2. Penetrations of fire resistive walls, floor - ceiling and roof shall be protected as required in UBC Sections 709 and 710.
3. Provide noncombustible blocking behind all fixtures, handles, grab bars, etc., where indicated or required.

EXITS

1. All exits are to be openable from the inside without the use of a key or special knowledge

JMB
ARCHITECTURE
ARCHITECTURE
PLANNING

4767 HIGHWAY 96 PO BOX 1170
WILLOW CREEK, CA 95573
707.629.0010 fax 707.629.2348
email: jmbarchitect@snowcrest.net

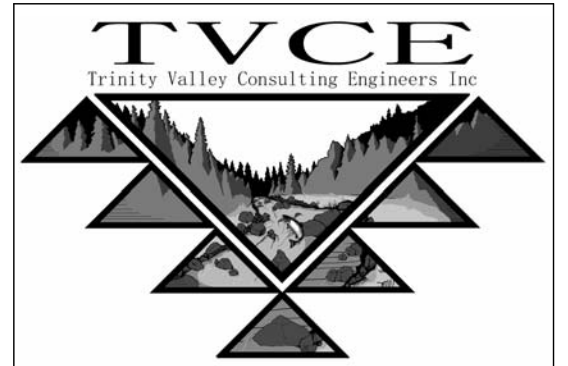

67 Walnut Way PO BOX 1567
WILLOW CREEK, CA 95573
707.629.3000 fax 707.629.3011
email: tvce@tvce.biz

Electrical Consultant	Peace Engineering
Address	1730 South Street Redding, CA 96001
Phone	530 244-0202
Fax	530 244
e-mail	
Bldg. Energy Consultant	Abbay Technical Services
Address	Anny McQuerry 1125 16th Street, Ste. 216 Arcata, CA 95521
Phone	707 826.1433
Fax	707-826-1430
e-mail	anny@abbaytechnicalservices.com

KARUK TRIBE
HOUSING AUTHORITY
Two Bedroom House

No.	Description	Date

GENERAL NOTES

Project number	ktha 2015
Date	07/05/2015
Drawn by	RKH
Checked by	JMB

G2
Scale

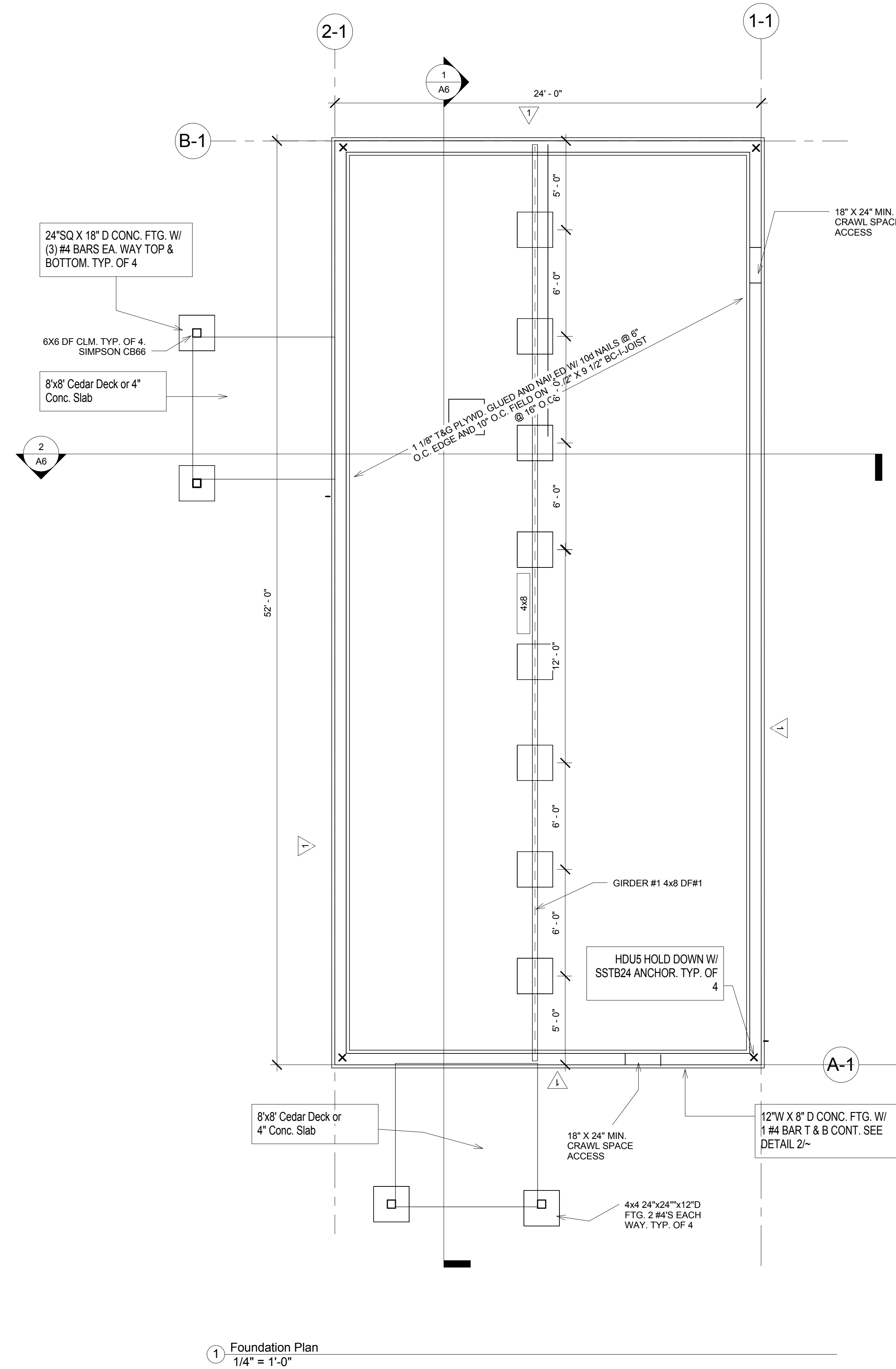
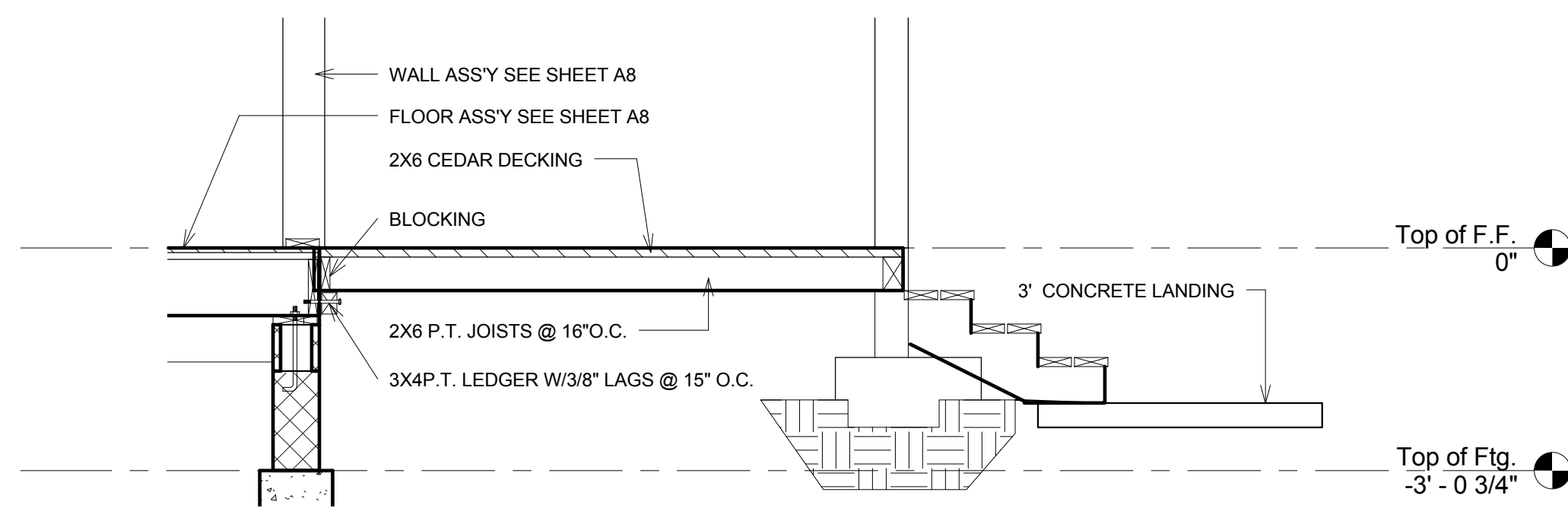
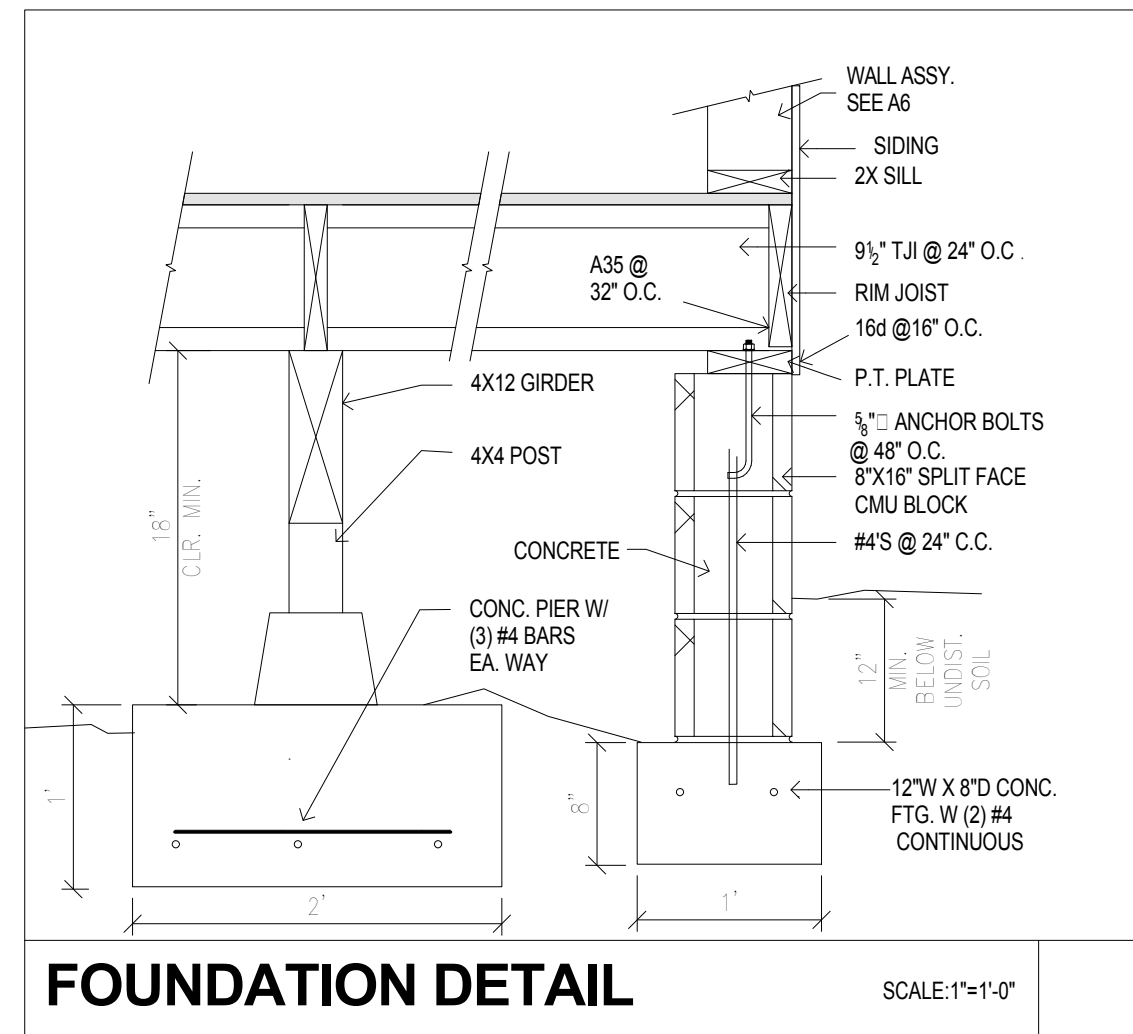

JMB
ARCHITECTURE
ARCHITECTURE
PLANNING

4767 HIGHWAY 96 PO BOX 1170
WILLOW CREEK, CA 95573
707.629.0010 fax 707.629.2348
email: jmbarchitect@snowcrest.net



67 Walnut Way PO BOX 1567
WILLOW CREEK, CA 95573
707.629.3000 fax 707.629.3011
email: tvce@tvce.biz

Electrical Consultant Pace Engineering

Address 1730 South Street
Reading, CA 96001
Phone 530 244-0202
Fax 530 244
e-mail

Bldg. Energy Consultant Abbey Technical Services
Address 1125 16th Street, Ste. 216
Arcata, CA 95521
Phone 707.826.1433
Fax 707-826-1430
e-mail ann@abbaytechnicalservices.com

KARUK TRIBE
HOUSING AUTHORITY
Two Bedroom House

No.	Description	Date

Foundation Plan

Project number ktha 2015
Date 07/05/2015
Drawn by RKH
Checked by JMB

S1

Scale As indicated



KARUK TRIBE
HOUSING AUTHORITY
Two Bedroom House

No.	Description	Date

Framing Plan

Project number	ktha 2015
Date	07/05/2015
Drawn by	RKH
Checked by	JMB

S2

Scale 1/4" = 1'-0"

GABLE VENT

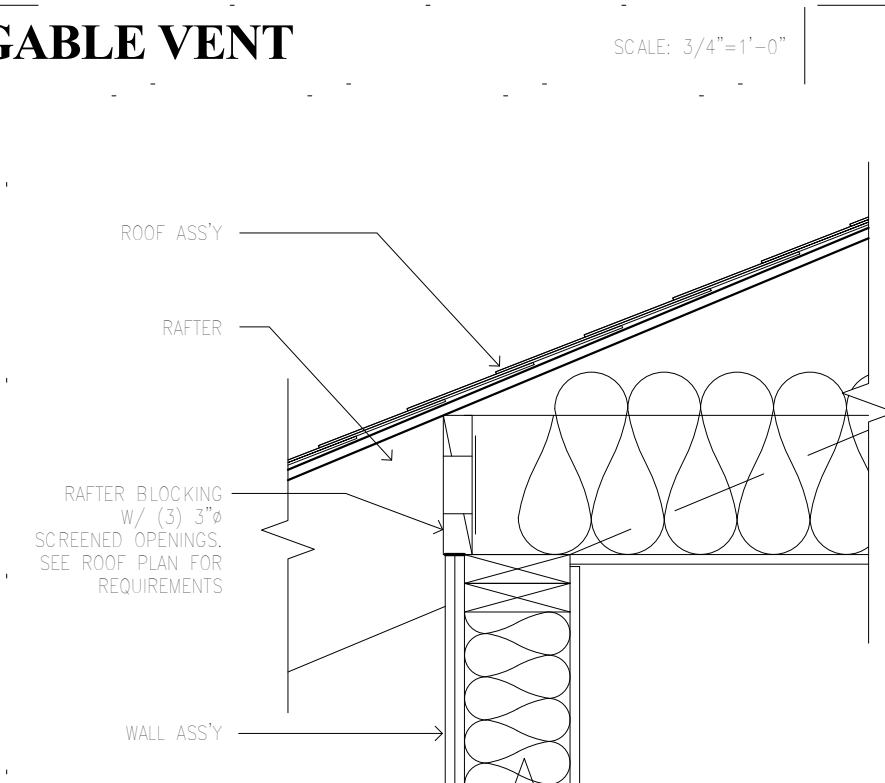

SOFFIT VENT

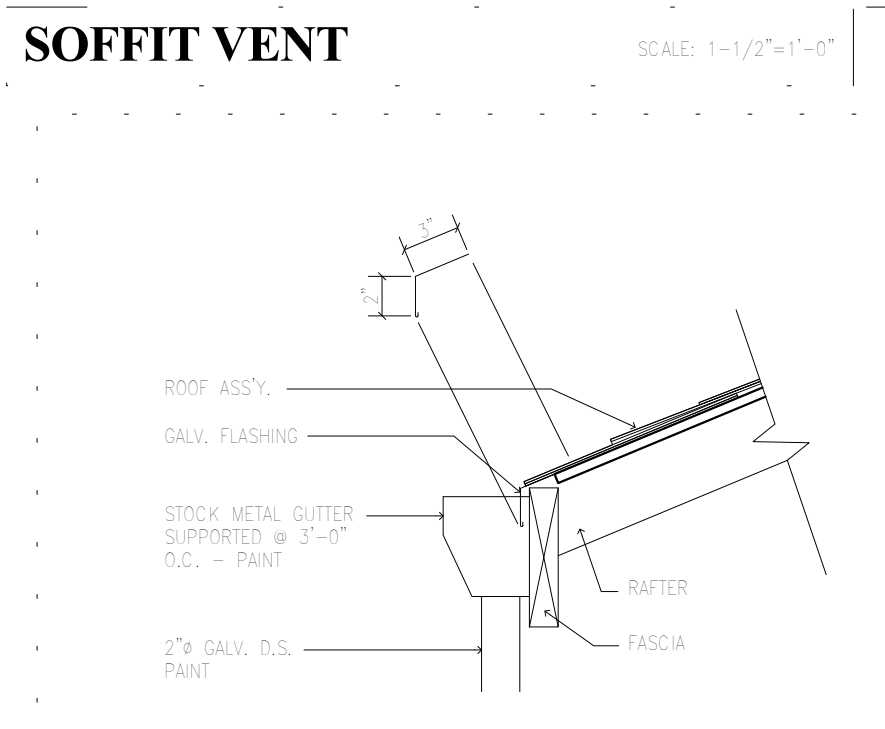

GUTTER DETAIL



Note:
All Headers 6X12 DF #2 U.N.O.

Shearwall Schedule

Wall Line	Story	Sheathing	Framing	Nailing	Anchor Bolts	Connections	Other
1-1	1	T-111 Sliding	2X6 @ 16" o.c.	8d @ 6" edge, 12" field	5/8" X 10" @ 48" o.c.	H2.5 @ EA Truss	
2-1	1	T-111 Sliding	2X6 @ 16" o.c.	8d @ 6" edge, 12" field	5/8" X 10" @ 48" o.c.	H2.5 @ EA Truss	
A-1	1	T-111 Sliding	2X6 @ 16" o.c.	8d @ 6" edge, 12" field	5/8" X 10" @ 48" o.c.		
B-1	1	T-111 Sliding	2X6 @ 16" o.c.	8d @ 6" edge, 12" field	5/8" X 10" @ 48" o.c.		

1 Framing Plan
1/4" = 1'-0"

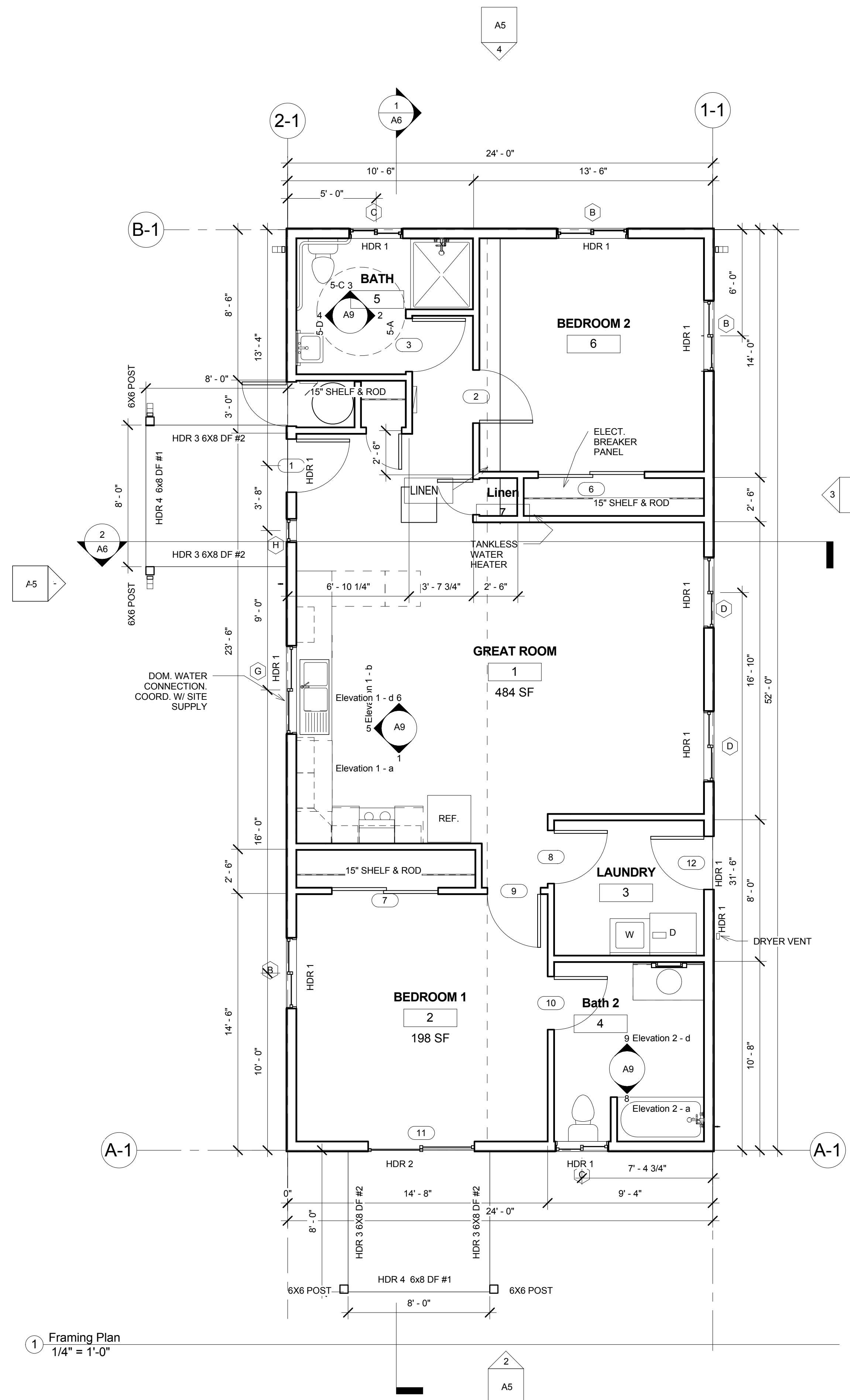

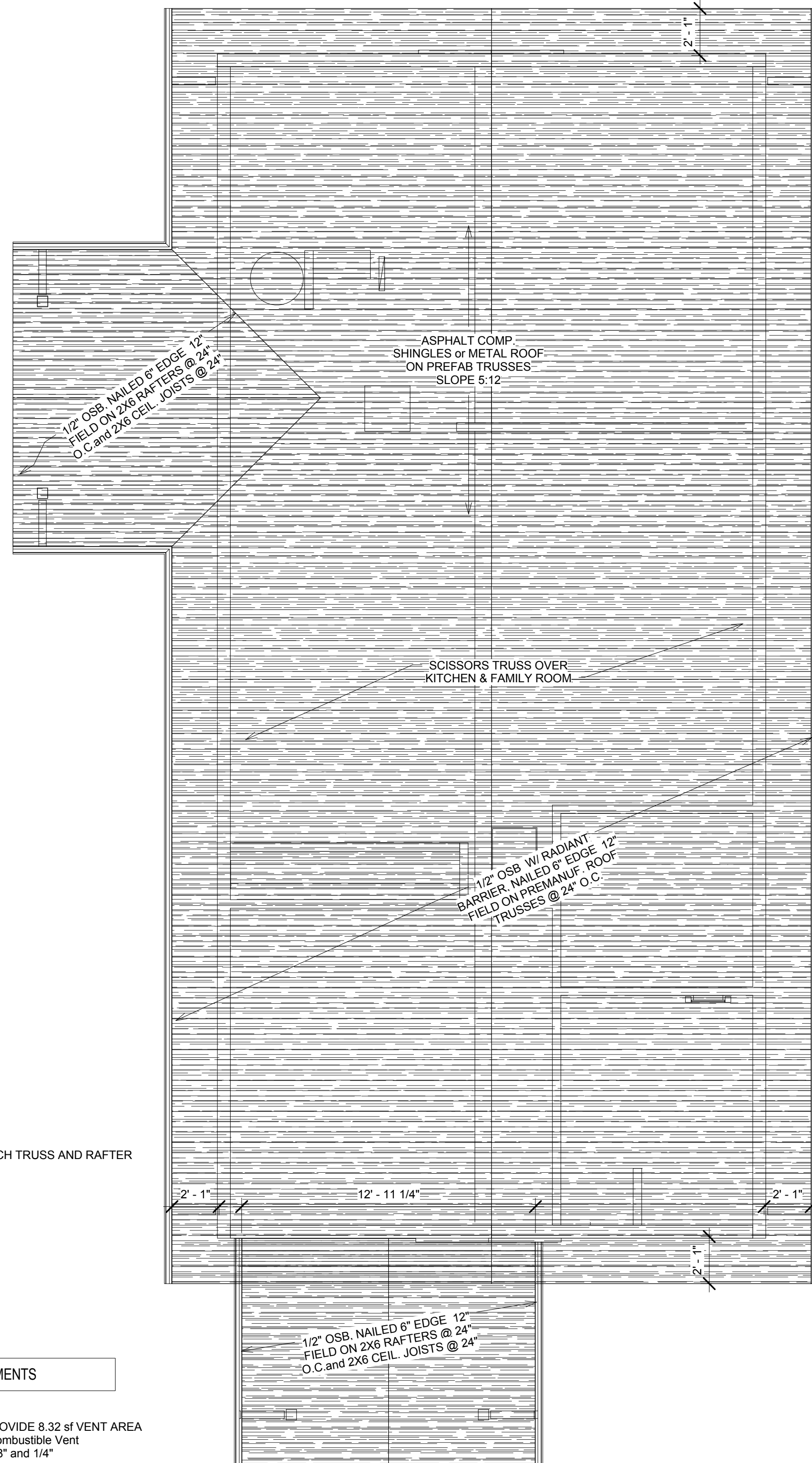

ATTIC VENT REQUIREMENTS
 ATTIC AREA: 1248 sf
 1248/150= 8.32 sf
 GABLE VENTS MUST PROVIDE 8.32 sf VENT AREA
 Corrosion resistant, non-combustible Vent
 with openings between 1/8" and 1/4"

3 Roof Plan
 1/4" = 1'-0"

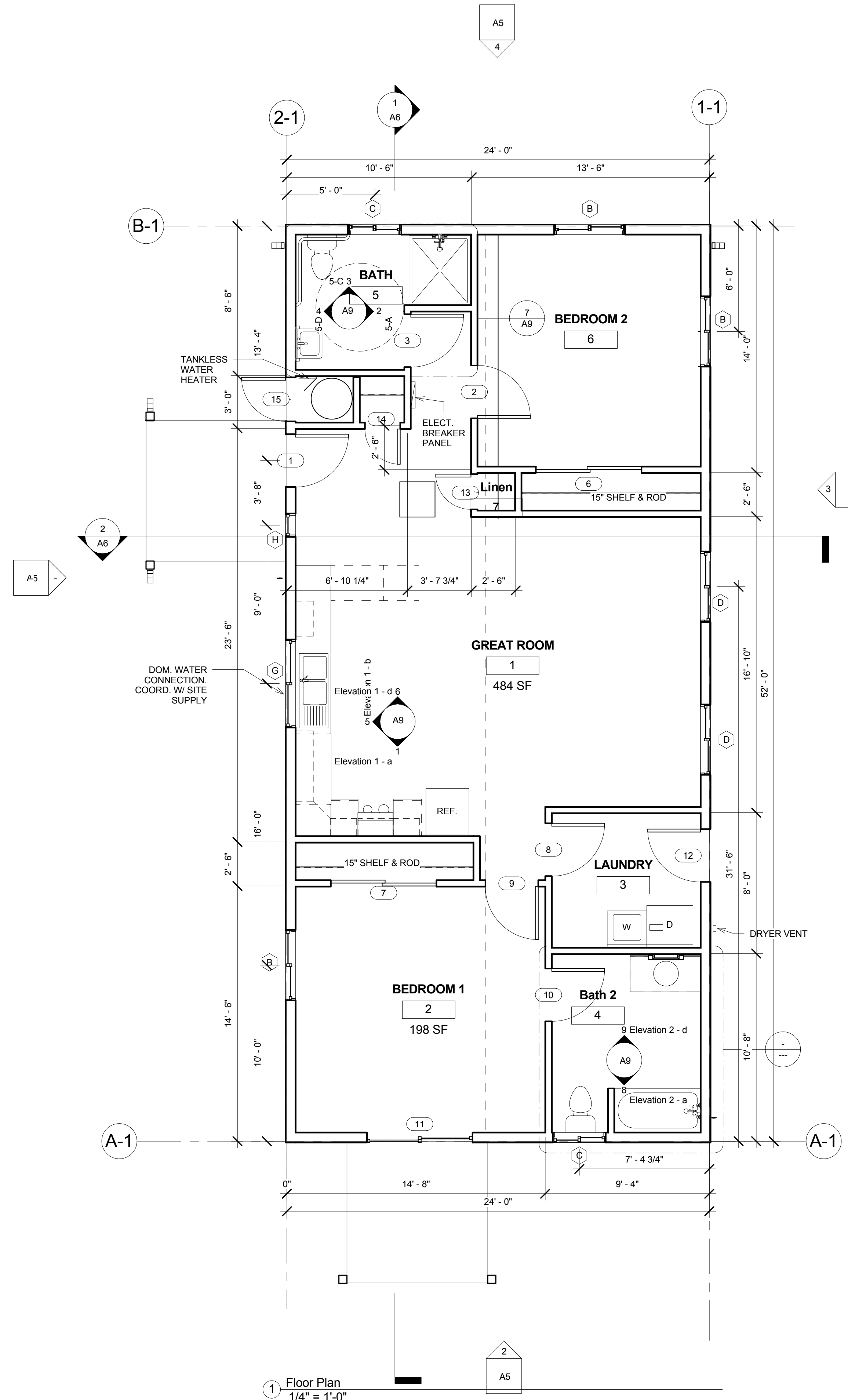

1 Floor Plan
 1/4" = 1'-0"

JMB ARCHITECTURE
 ARCHITECTURE PLANNING
 4767 HIGHWAY 96 PO BOX 1170
 WILLOW CREEK, CA 95573
 707.629.0010 fax 707.629.2348
 email: jmbarchitect@snowcrest.net

TVCE
 Trinity Valley Consulting Engineers, Inc.
 67 Walnut Way PO BOX 1567
 WILLOW CREEK, CA 95573
 707.629.3000 fax 707.629.3011
 email: tvce@tvce.biz

Electrical Consultant: Pace Engineering
 Address: 1730 South Street Redding, CA 96001
 Phone: 530 244-0202
 Fax: 530 244
 e-mail:
 Bldg. Energy Consultant: Abbey Technical Services
 Address: Anny McQuerry 1125 16th Street, Ste. 216 Arcata, CA 95521
 Phone: 707.826.1433
 Fax: 707-826-1430
 e-mail: anny@abbeytechnicalservices.com

KARUK TRIBE HOUSING AUTHORITY
 Two Bedroom House

No.	Description	Date

FLOOR PLAN & ROOF PLAN
 Project number: ktha 2015
 Date: 07/05/2015
 Drawn by: RKH
 Checked by: JMB
A1
 Scale: 1/4" = 1'-0"

JMB
ARCHITECTURE
ARCHITECTURE
PLANNING

4767 HIGHWAY 96 PO BOX 1170
WILLOW CREEK, CA 95573
707.629.0010 fax 707.629.2348
email: jmbarchitect@snowcrest.net

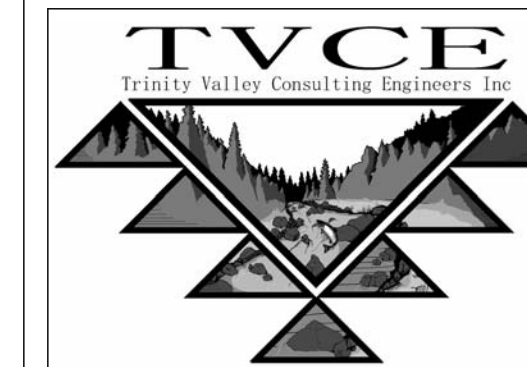

67 Walnut Way PO BOX 1567
WILLOW CREEK, CA 95573
707.629.3000 fax 707.629.3011
email: tvce@tvce.biz

KARUK TRIBE
HOUSING AUTHORITY
Two Bedroom House

No.	Description	Date

Elevations

Project number ktha 2015
Date 07/05/2015
Drawn by RKH
Checked by JMB

A5

Scale 1/4" = 1'-0"

8/7/2015 4:55:31 PM

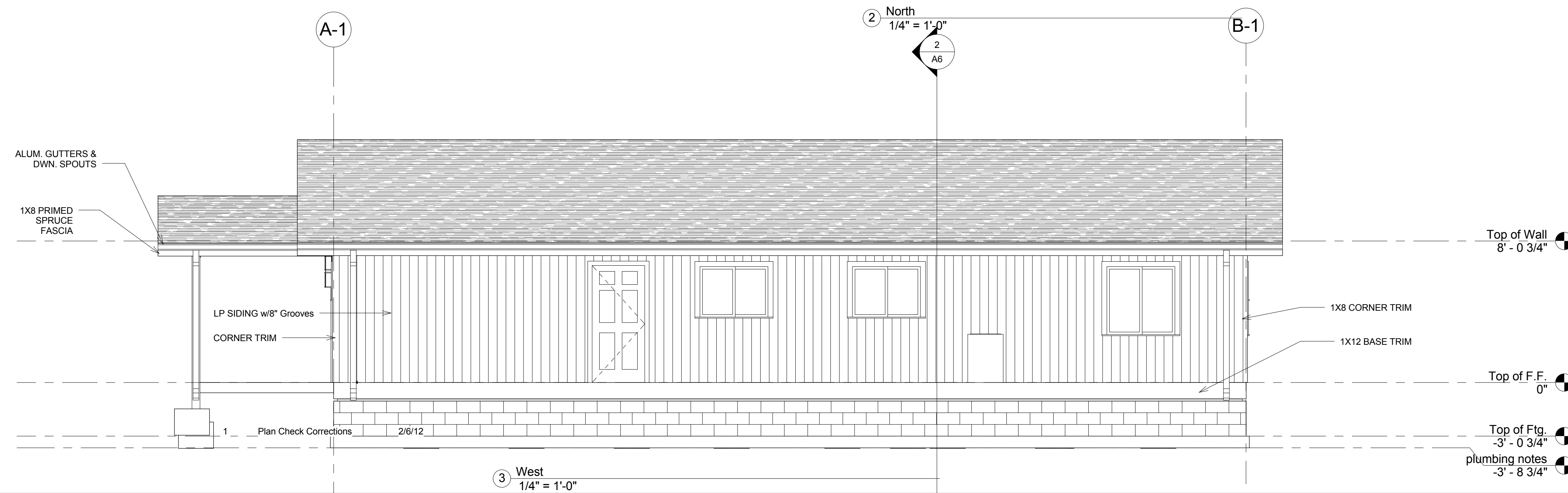
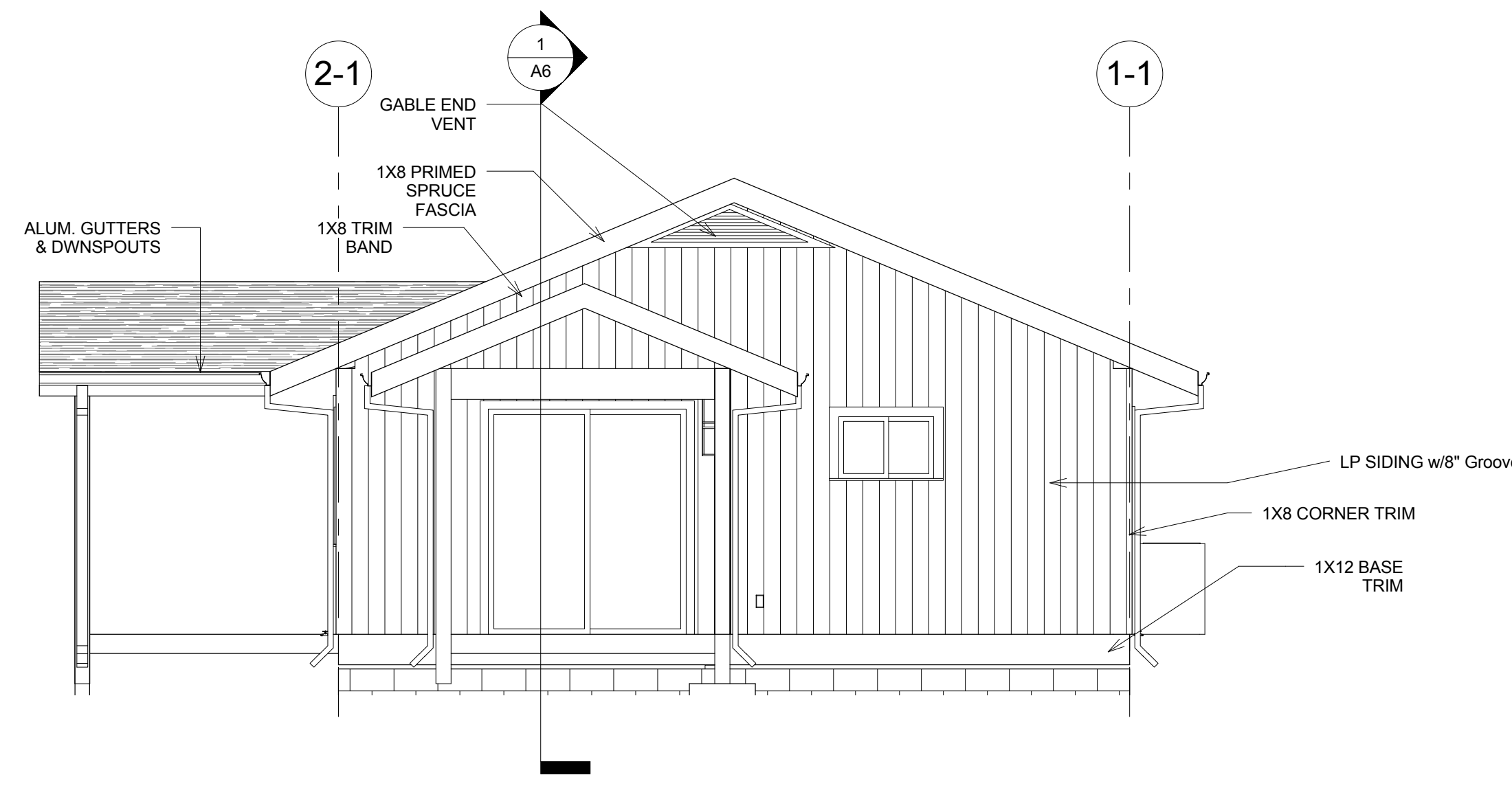
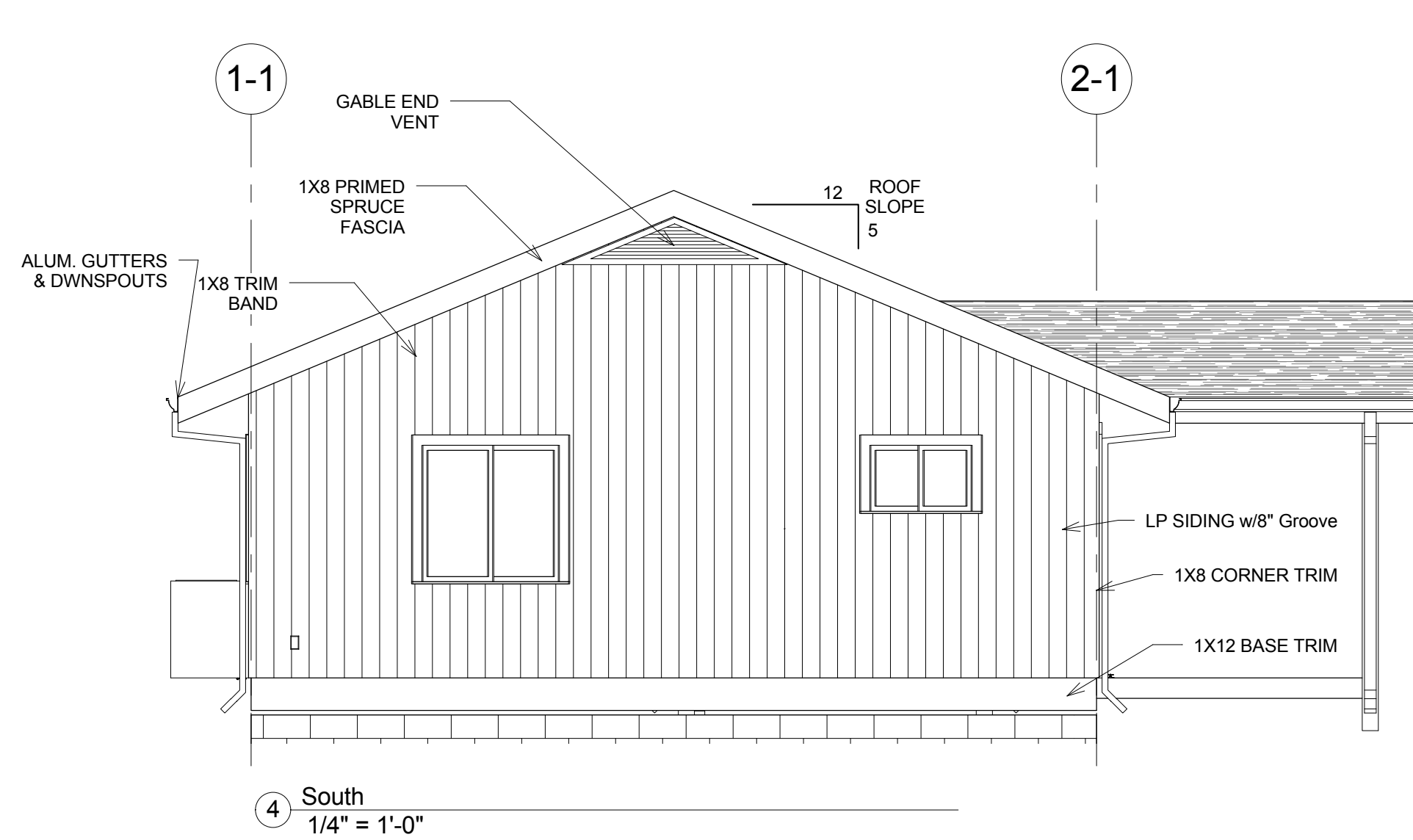
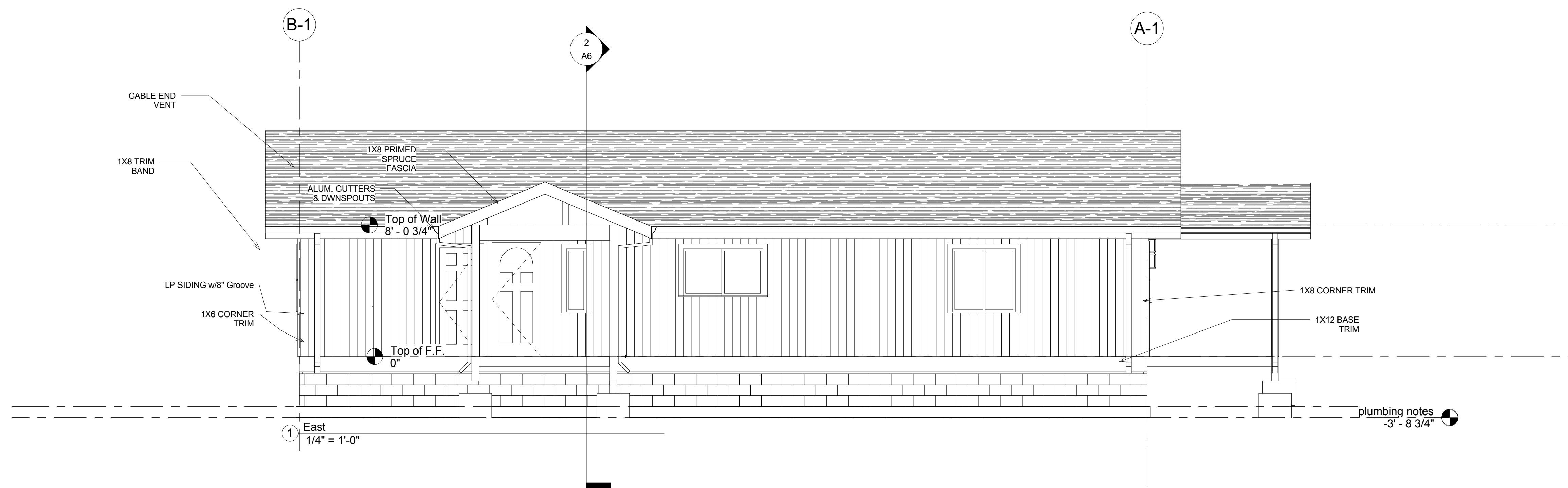

West
1/4" = 1'-0"

JMB
ARCHITECTURE
ARCHITECTURE
PLANNING

4767 HIGHWAY 96 PO BOX 1170
WILLOW CREEK, CA 95573
707.629.0010 fax 707.629.2348
email: jmbarchitect@snowcrest.net

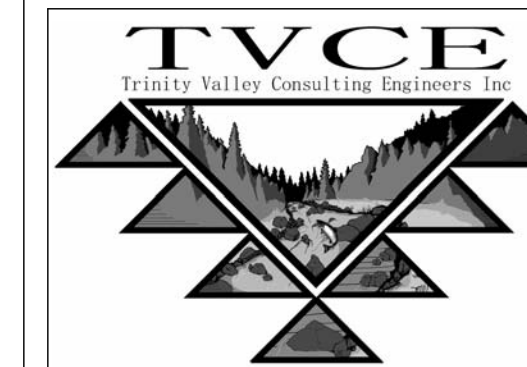

67 Walnut Way PO BOX 1567
WILLOW CREEK, CA 95573
707.629.3000 fax 707.629.3011
email: tvce@tvce.biz

Electrical Consultant Pace Engineering

Address 1730 South Street
Reading, CA 96001
Phone 530 244-0202
Fax 530 244
e-mail

Bldg. Energy Consultant Abby Technical Services
Address 1125 16th Street, Ste. 216
Arcata, CA 95521
Phone 707-826-1433
Fax 707-826-1430
e-mail ann@abbaytechnicalservices.com

KARUK TRIBE
HOUSING AUTHORITY
Two Bedroom House

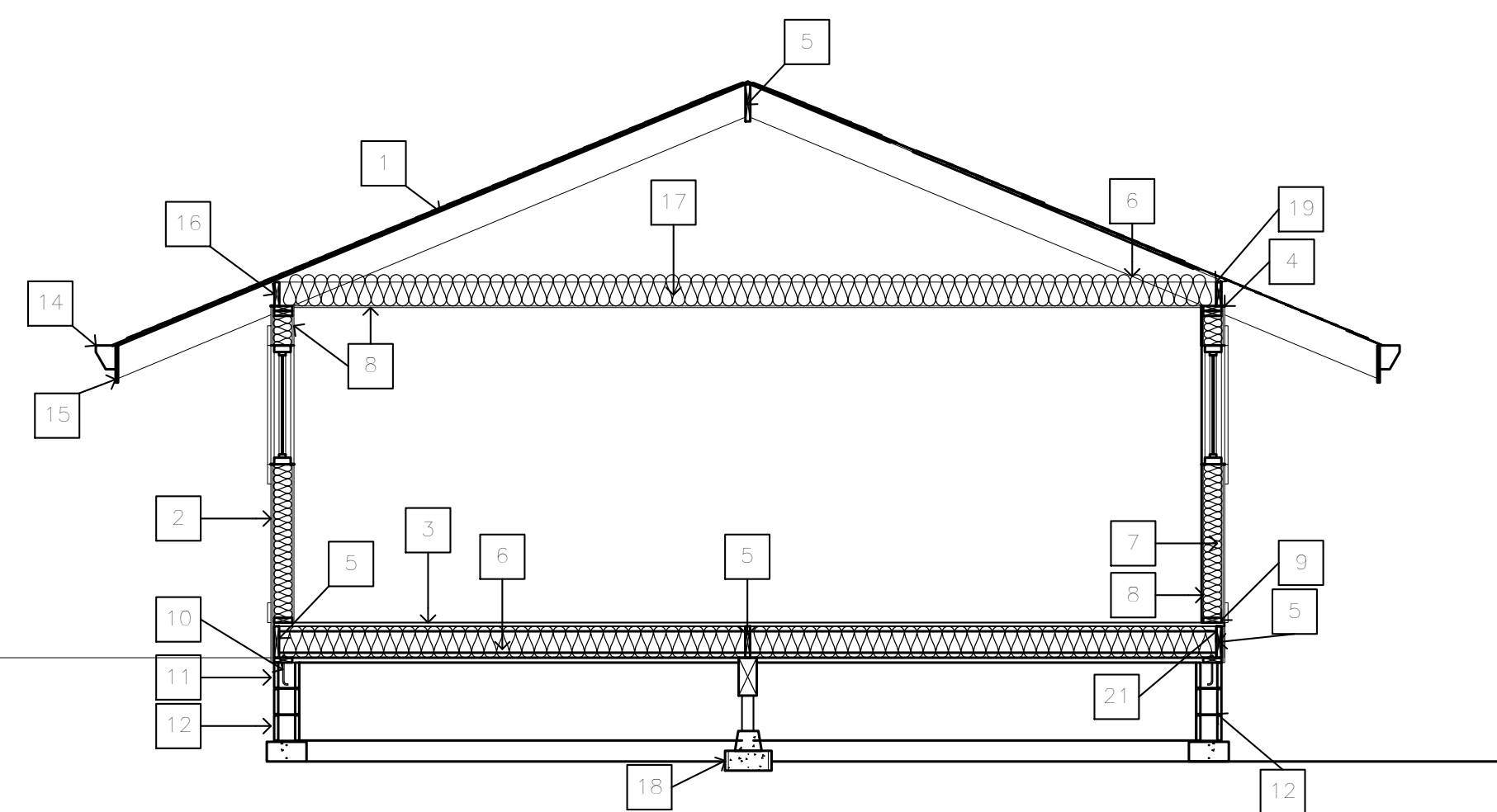
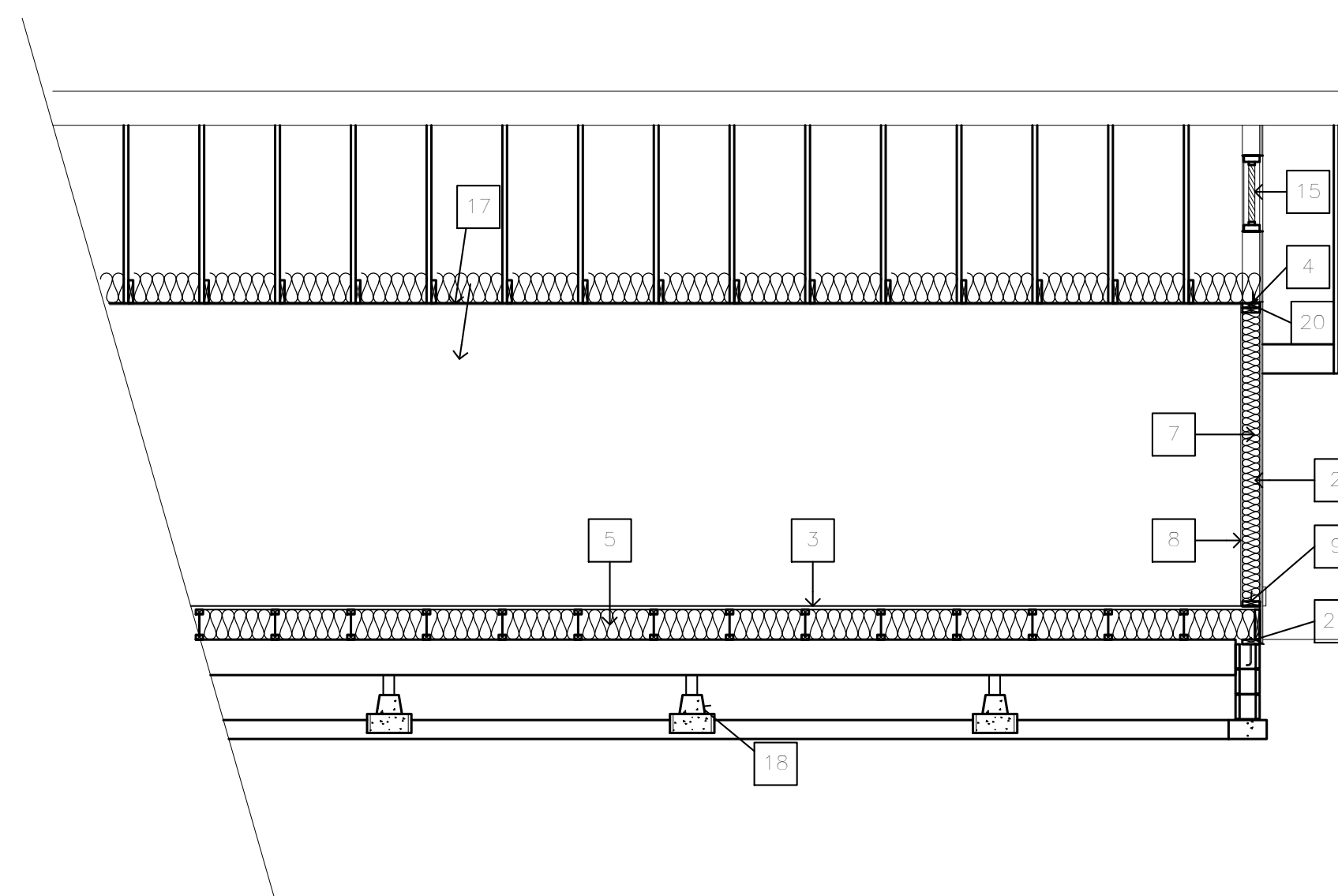
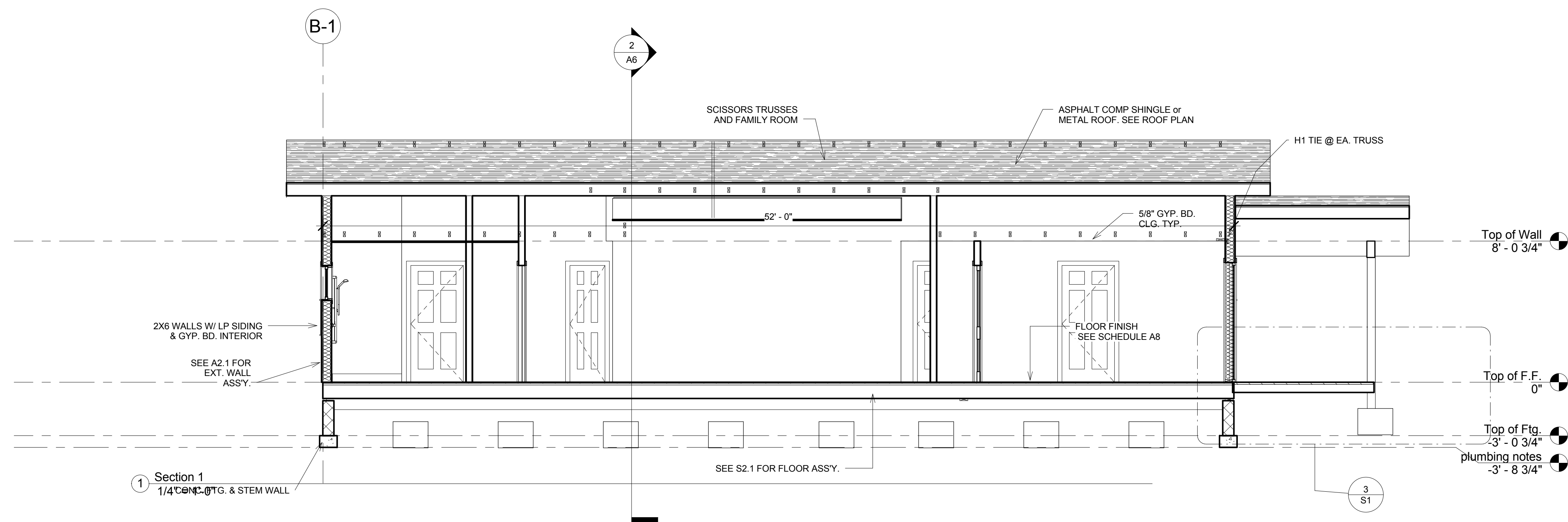

- KEYNOTE LEGEND**
- ROOFING - ASPHALT COMP. SHINGLES OVER 1/2" OSB SHTG. OVER 2 LAYERS #15 FELT OVER MANUFACTURED TRUSSES @ 24" O.C. NAILING PER TABLE 23-II-B-2.
 - WALLS - SIDING OVER 2 LAYERS #15 FELT OVER 1/2" OSB SHTG. ON 2X6 STUDS @ 16" OC
 - FLOORING - 1-1/8" SHTG. OVER 9-1/4" JOISTS @ 16" O.C. UNO SEE SCHEDULE SHEET A8 FOR FLR. FINISH
 - 2X6 DBL TOP PLATE
 - BLOCKING
 - R38 INSULATION
 - R21 INSULATION
 - 1/2" DRYWALL
 - 2X6 P. T. SILL
 - 5/8" DIA. A.B. @ 4'-0" OC
 - CMU STEM WALL W/ VERTS @ 24" C.C. & (1) #4 HORIZ. CONT.
 - 6"x12" FOOTING W/ (1) #4 T&B
 - GABLE VENT
 - GSM GUTTER & DWN SPOUTS
 - 2X10 FASCIA
 - SOFFIT VENT
 - TRUSSES W/ 5/8" GYP. BD CEILING
 - CONC. PIER BLOCK & 24"x24"x12"D FTG W/ (3) #4 BARS EA WAY
 - H1 TIE @ EA TRUSS
 - A35 @ 32" O.C. TRUSS BLOCKING TO TOP PLATE
 - A35 @ 32" O.C. RIM JOIST TO SILL

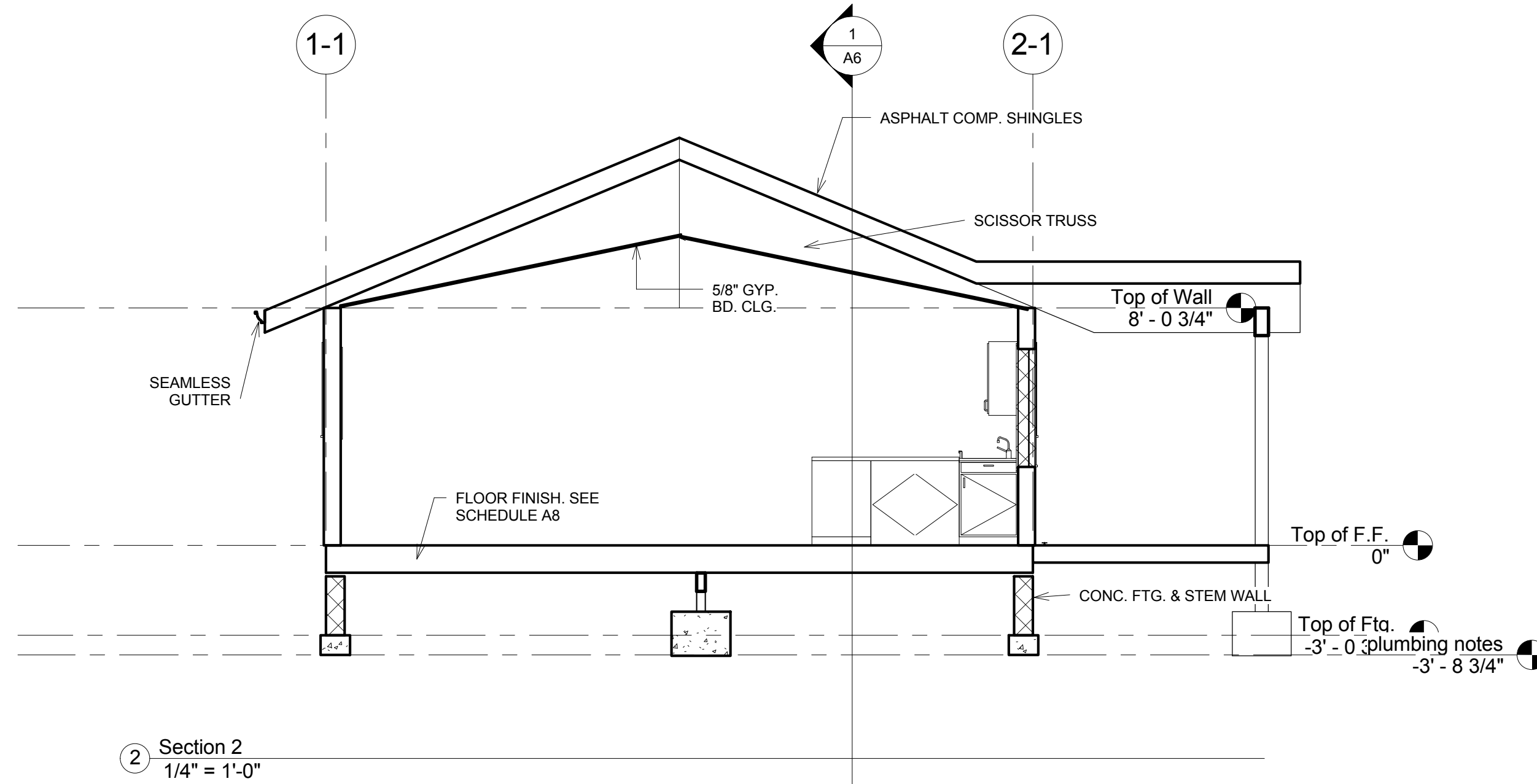

No.	Description	Date

Building Sections

Project number ktha 2015
Date 07/05/2015
Drawn by RKH
Checked by JMB

Scale 1/4" = 1'-0"

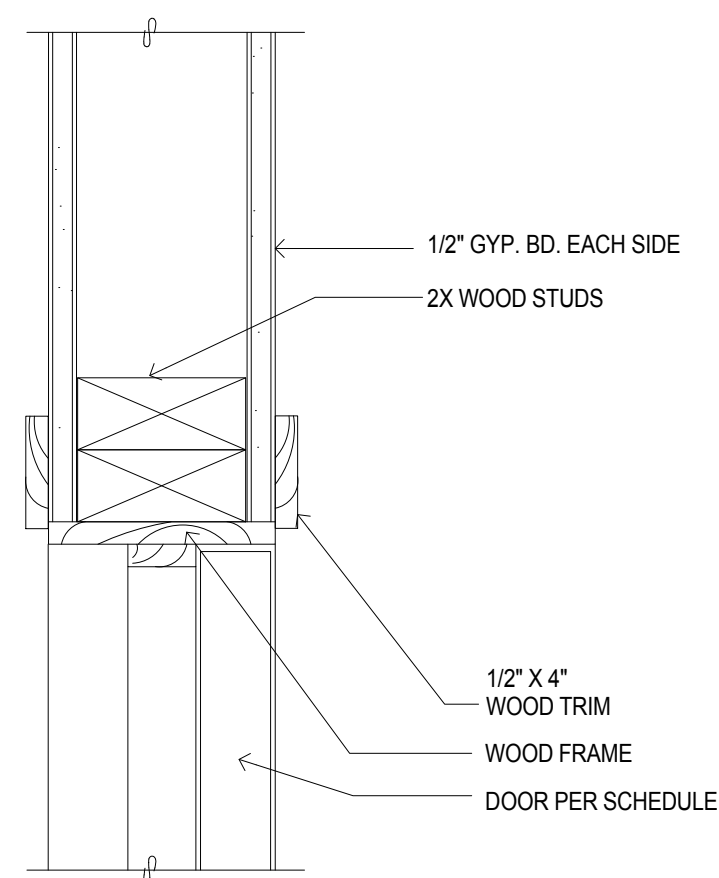

HEAD@INTERIOR DOOR

SCALE: 3"=1'-0"

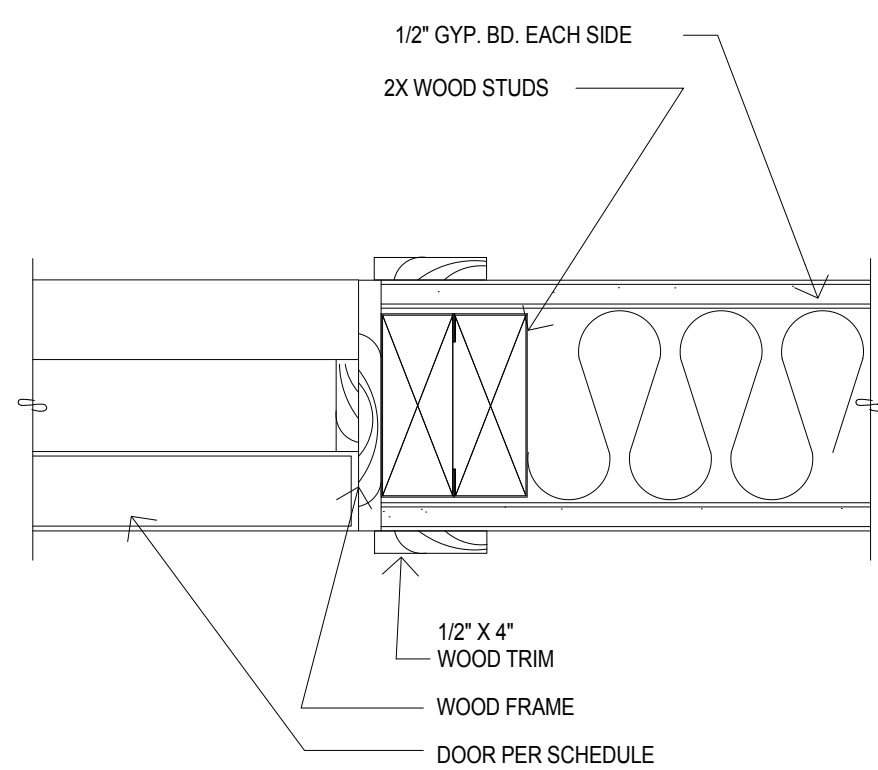

JAMB@INTERIOR DOOR

SCALE: 3"=1'-0"

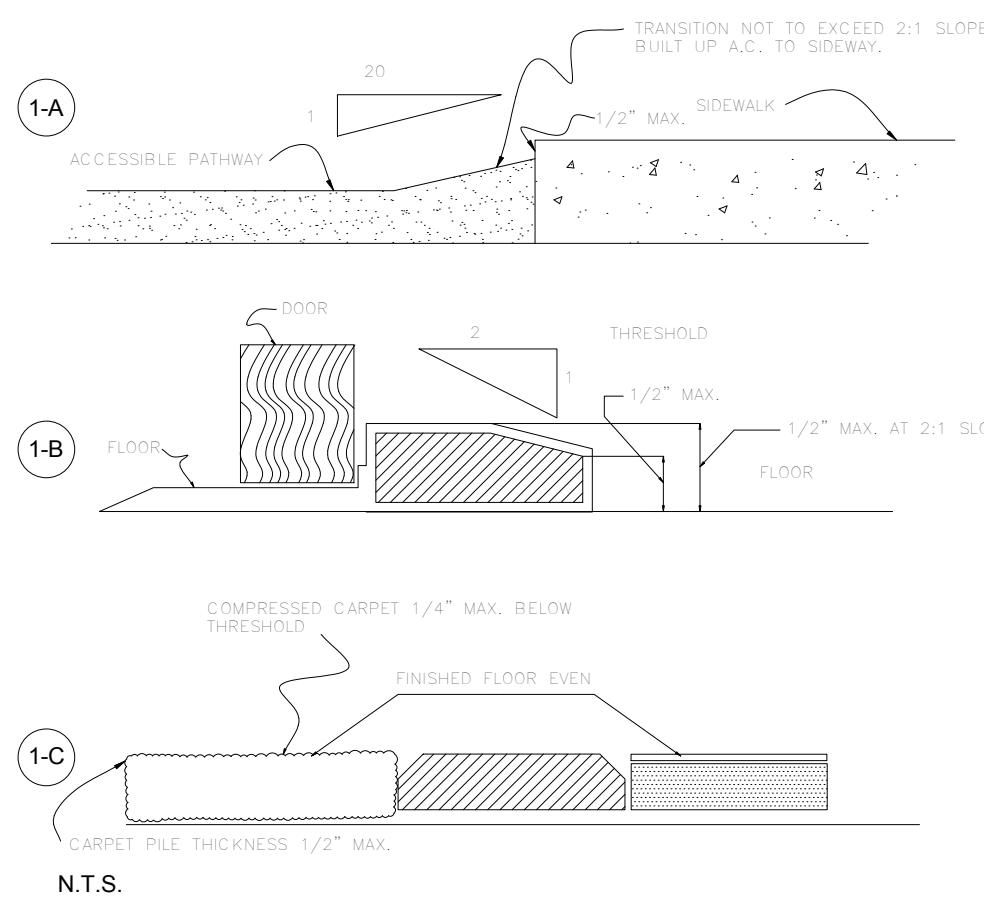

THRESHOLD DETAIL

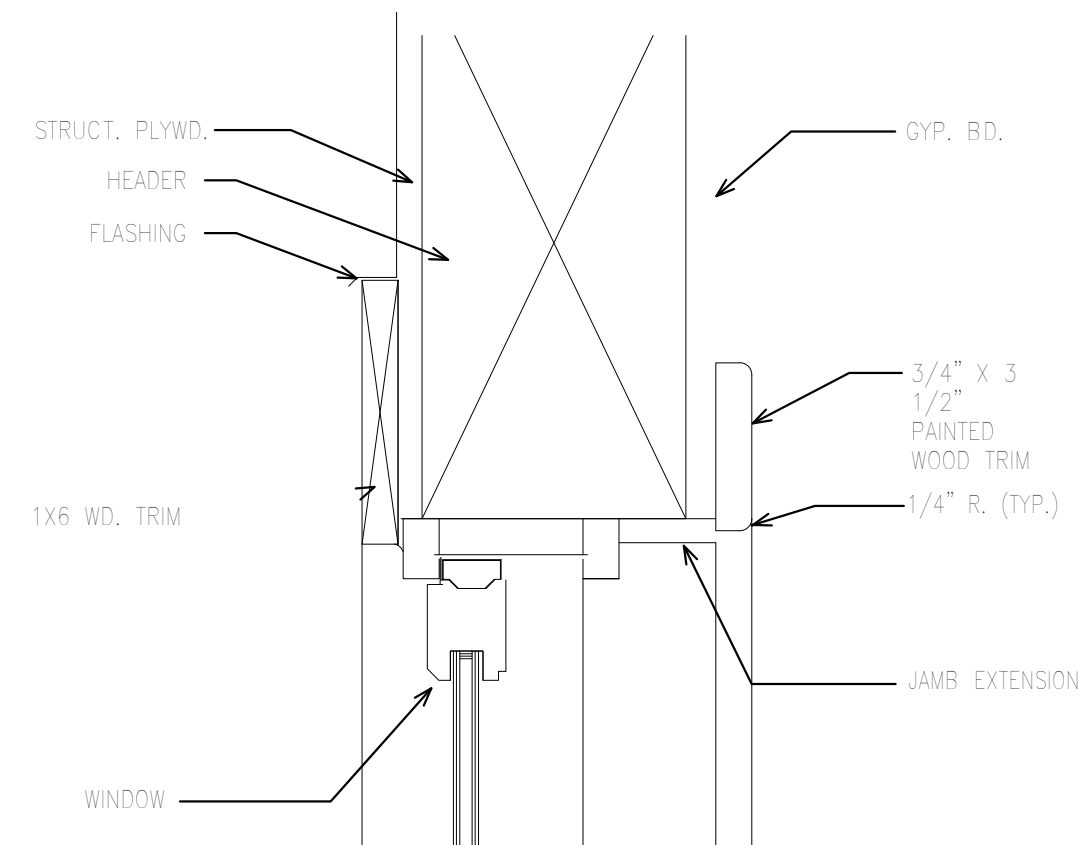

WINDOW HEAD DETAIL

SCALE: 3"=1'-0"

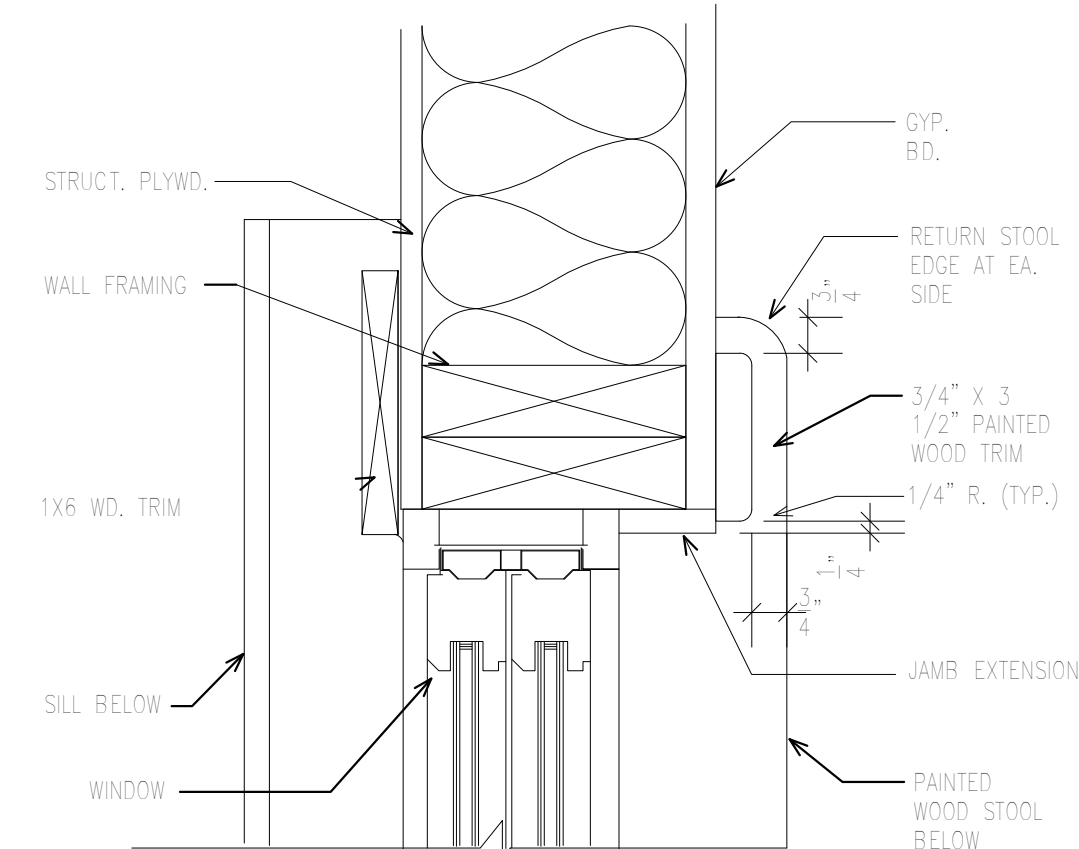

WINDOW JAMB DETAIL

SCALE: 3"=1'-0"

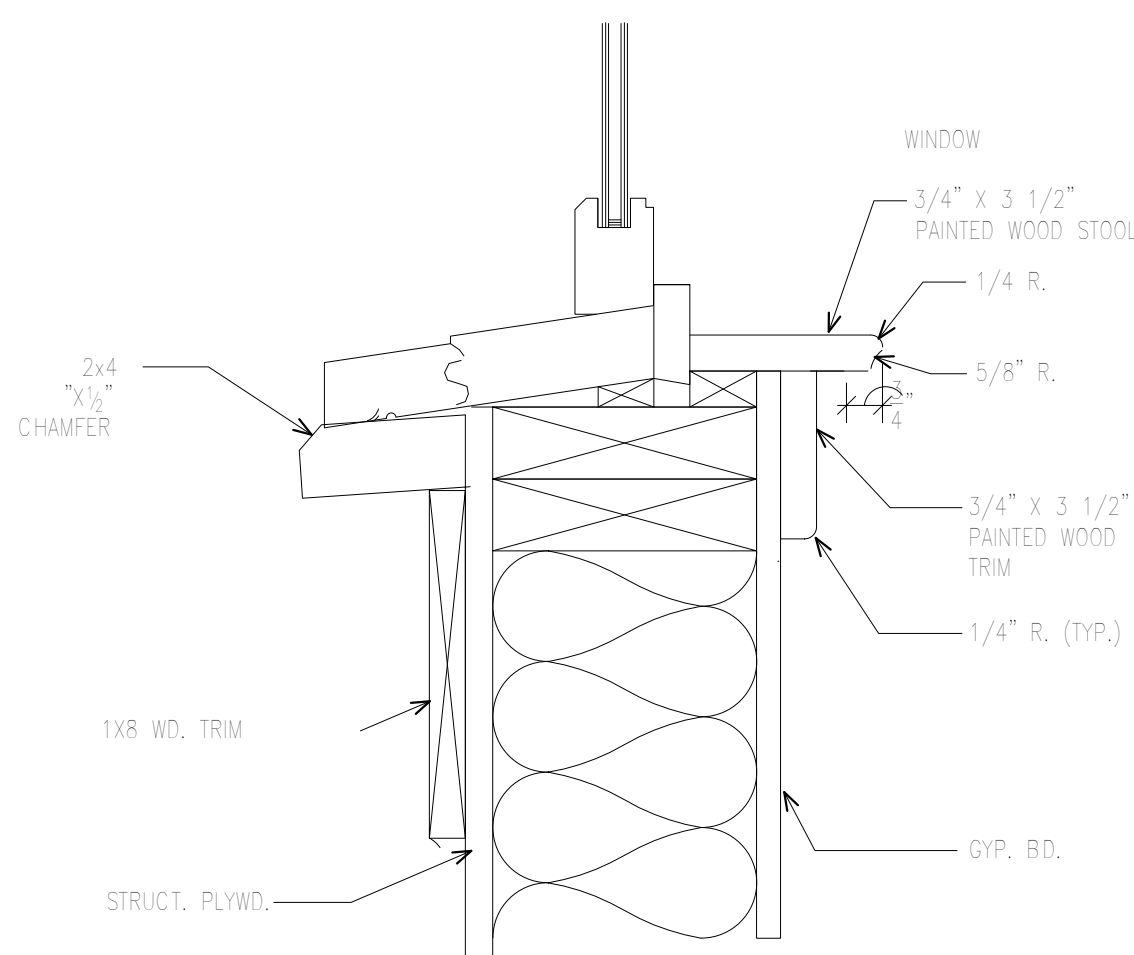

WINDOW SILL

SCALE: 3"=1'-0"

Door Number	Door Type	Door Size	Description	Finish	
				Frame	Comments
1	34	36" x 80"	EXTERIOR	1 3/4"	
2	23	36" x 80"	INTERIOR	1 3/8"	
3	23	36" x 80"	INTERIOR	1 3/8"	
6	3	72" x 80"	SLIDING CLOSET	1 3/8"	
7	3	72" x 80"	SLIDING CLOSET	1 3/8"	
8	23	36" x 80"	INTERIOR	1 3/8"	
9	23	36" x 80"	INTERIOR	1 3/8"	
10	23	36" x 80"	INTERIOR	1 3/8"	
11	62	72" x 82"	SLIDING GLASS	1 3/4"	
12	23	36" x 80"	INTERIOR	1 3/8"	
13	39	24" x 80"	INTERIOR	1 3/8"	
14	39	24" x 80"	INTERIOR	1 3/8"	
15	22	30" x 80"	EXTERIOR	1 3/4"	

Type Mark	Rough Opening		Type	Material	Glazing Type	Head Height	Comments
	Width	Height					
B	4' - 0"	4' - 0"	Slider with Trim	VINYL		6' - 8"	
C	3' - 0"	2' - 0"	Slider with Trim	VINYL		6' - 8"	
D	4' - 0"	3' - 0"	Slider with Trim	VINYL		6' - 8"	
G	5' - 0"	3' - 0"	Slider with Trim	VINYL		6' - 8"	
H	1' - 4"	4' - 0"	Fixed with Trim	VINYL		6' - 8"	

Type Mark	Family and Type	Manufacturer	Model	Lamp	Type Comments
	Ceiling Light - Flat Round: 60W - 120V			A-19	
	Outdoor Wall Sconce Wall Mount : CB3325-2N75(120V)[BC BL][TC TL]	Visa Lighting Milwaukee WI USA (800-788-VISA)	CB3325	75W MED A19 Incandescent	

Room Number	Room Name	Finish				Comments
		Floor	Base	Wall	Ceiling	
1	GREAT ROOM	Vinyl/Laminate	4" MDF Painted	GYP BD	GYP BD ceil. hgt varries	orange peel finish all walls and ceiling
2	BEDROOM 1	Carpet	4" MDF Painted	GYP BD	GYP BD ceil hgt 8'	orange peel finish all walls and ceiling
3	LAUNDRY	Vinyl/Laminate	4" MDF Painted	GYP BD	GYP BD ceil hgt 8'	orange peel finish all walls and ceiling
4	Bath 2	Vinyl/Laminate	4" MDF Painted	GYP BD	GYP BD ceil hgt 8'	orange peel finish all walls and ceiling
5	BATH	Vinyl/Laminate	4" MDF Painted	GYP BD	GYP BD ceil hgt 8'	orange peel finish all walls and ceiling
6	BEDROOM 2	Carpet	4" MDF Painted	GYP BD	GYP BD ceil hgt 8'	orange peel finish all walls and ceiling
7	Linen	Vinyl/Laminate	4" MDF Painted	GYP BD	GYP BD ceil hgt 8'	orange peel finish all walls and ceiling

JMB ARCHITECTURE
 ARCHITECTURE PLANNING
 4767 HIGHWAY 96 PO BOX 1170
 WILLOW CREEK, CA 95573
 707.629.0010 fax 707.629.2348
 email: jmbarchitect@snowcrest.net

TVCE
 Trinity Valley Consulting Engineers Inc.
 67 Walnut Way PO BOX 1567
 WILLOW CREEK, CA 95573
 707.629.3000 fax 707.629.3011
 email: tvce@tvce.biz

Electrical Consultant Pace Engineering
 Address 1730 South Street Redding, CA 96001
 Phone 530 244-0202
 Fax 530 244
 e-mail
 Bldg. Energy Consultant Address 1125 16th Street, Ste. 216 Arcata, CA 95521
 Phone 707-826-1433
 Fax 707-826-1430
 e-mail ann@abbaytechnicalservices.com

KARUK TRIBE HOUSING AUTHORITY
 Two Bedroom House

No.	Description	Date

Schedules

Project number ktha 2015
 Date 07/05/2015
 Drawn by RKH
 Checked by JMB

A8

Scale

JMB
ARCHITECTURE
ARCHITECTURE
PLANNING

4767 HIGHWAY 96 PO BOX 1170
WILLOW CREEK, CA 95573
707.629.0010 fax 707.629.2348
email: jmbarchitect@snowcrest.net



67 Walnut Way PO BOX 1567
WILLOW CREEK, CA 95573
707.629.3000 fax 707.629.3011
email: tvce@tvce.biz

Electrical Consultant Pace Engineering
Address 1730 South Street
Reading, CA 96001
Phone 530 244-0202
Fax 530 244
e-mail

Bldg. Energy Consultant Abbey Technical Services
Address 1125 16th Street, Ste. 216
Arcata, CA 95521
Phone 707 826-1433
Fax 707-826-1430
e-mail anny@abbaytechnicalservices.com

KARUK TRIBE
HOUSING AUTHORITY
Two Bedroom House

No.	Description	Date

Interior Elevations

Project number ktha 2015
Date 07/05/2015
Drawn by RKH
Checked by JMB

A9

Scale 1/2" = 1'-0"

8/7/2015 4:50:05 PM

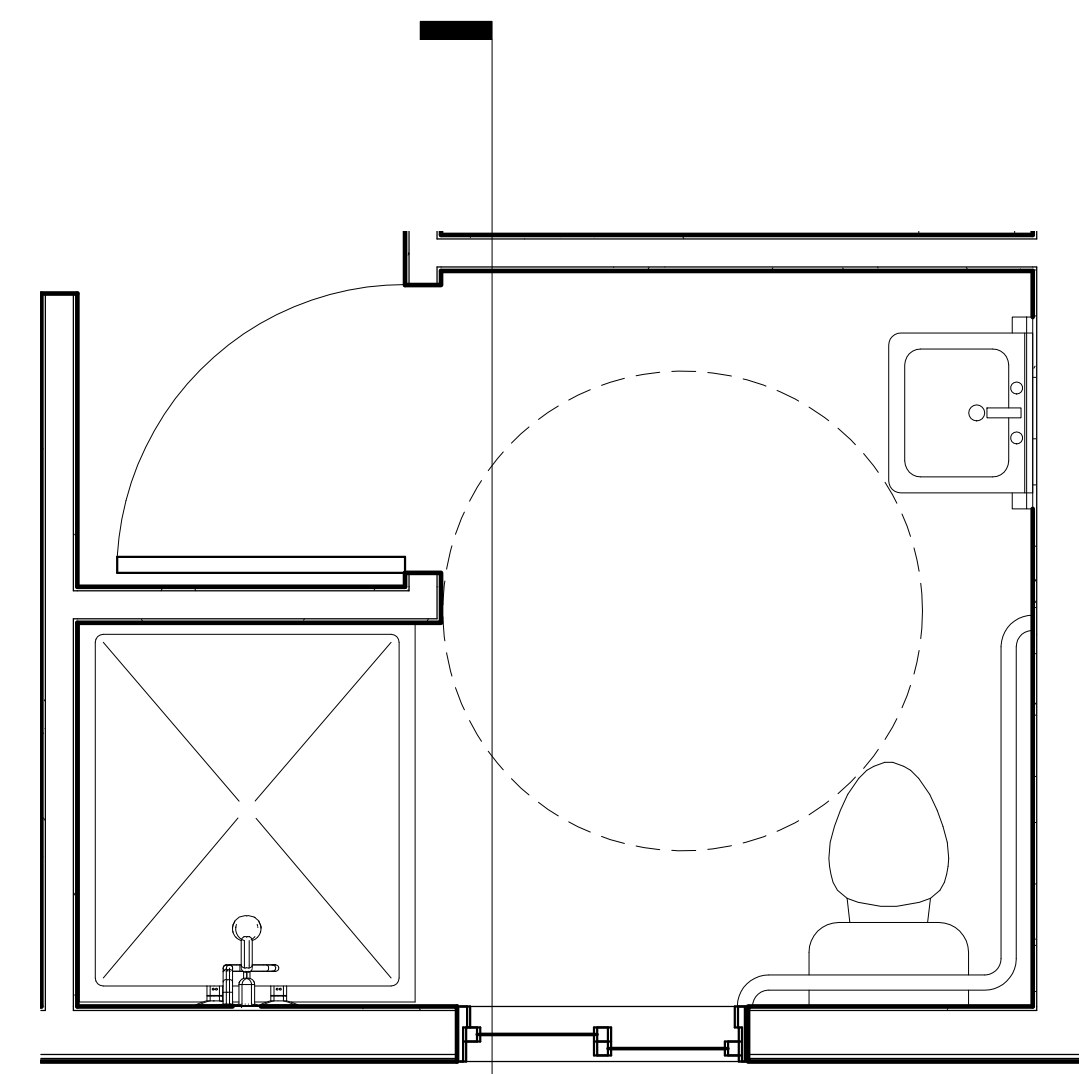

7 ENLARGED BATH PLAN
1/2" = 1'-0"

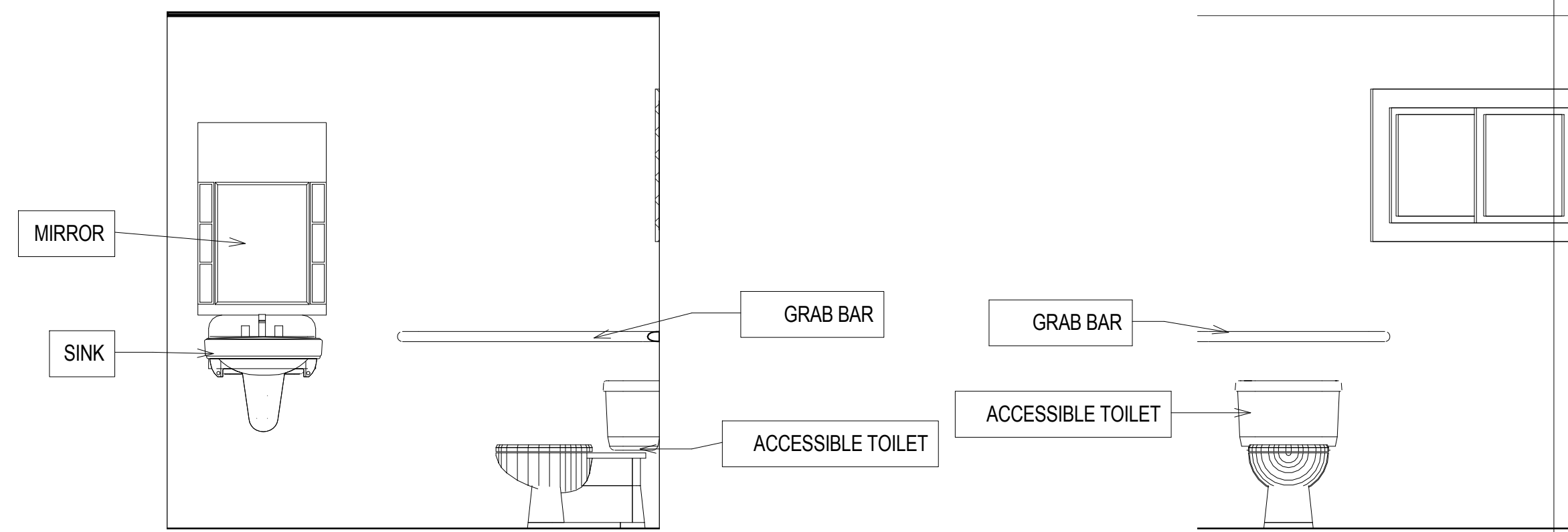

4 5-D
1/2" = 1'-0"

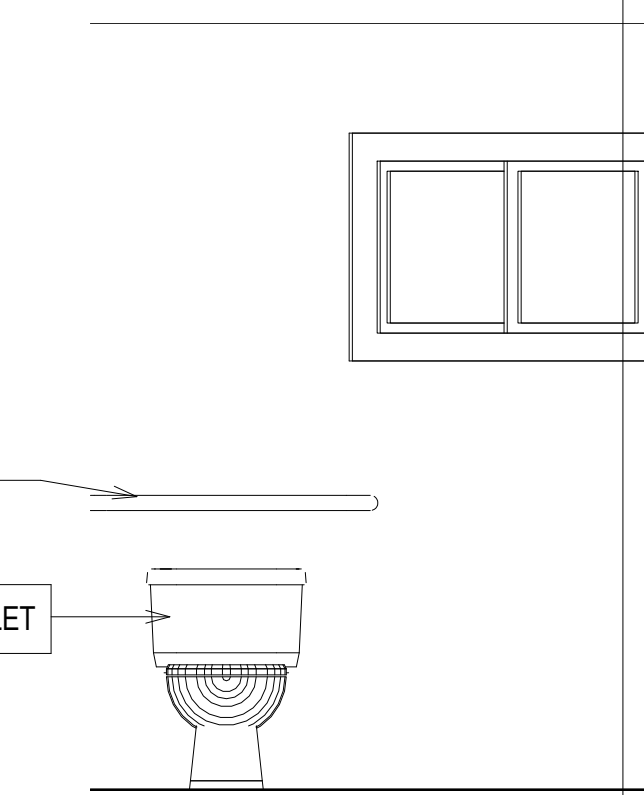

3 5-C
1/2" = 1'-0"

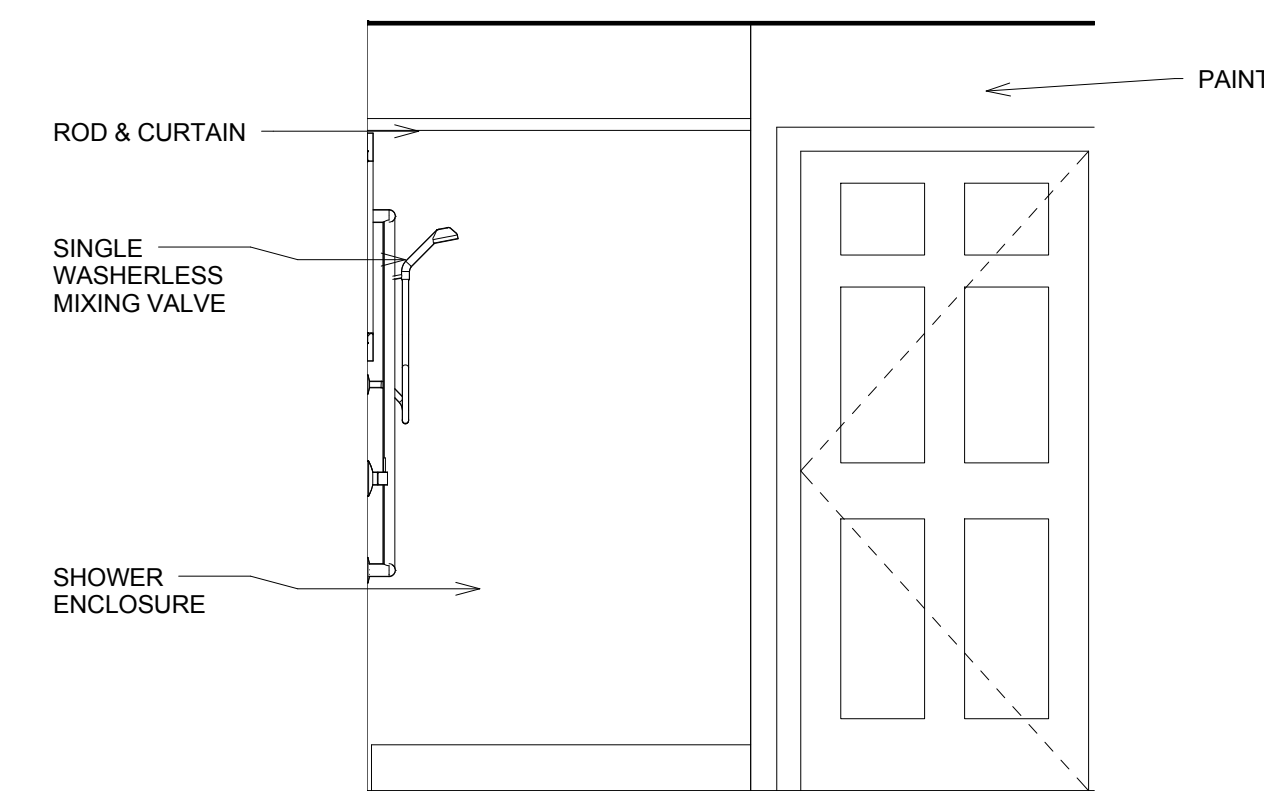

2 5-A
1/2" = 1'-0"

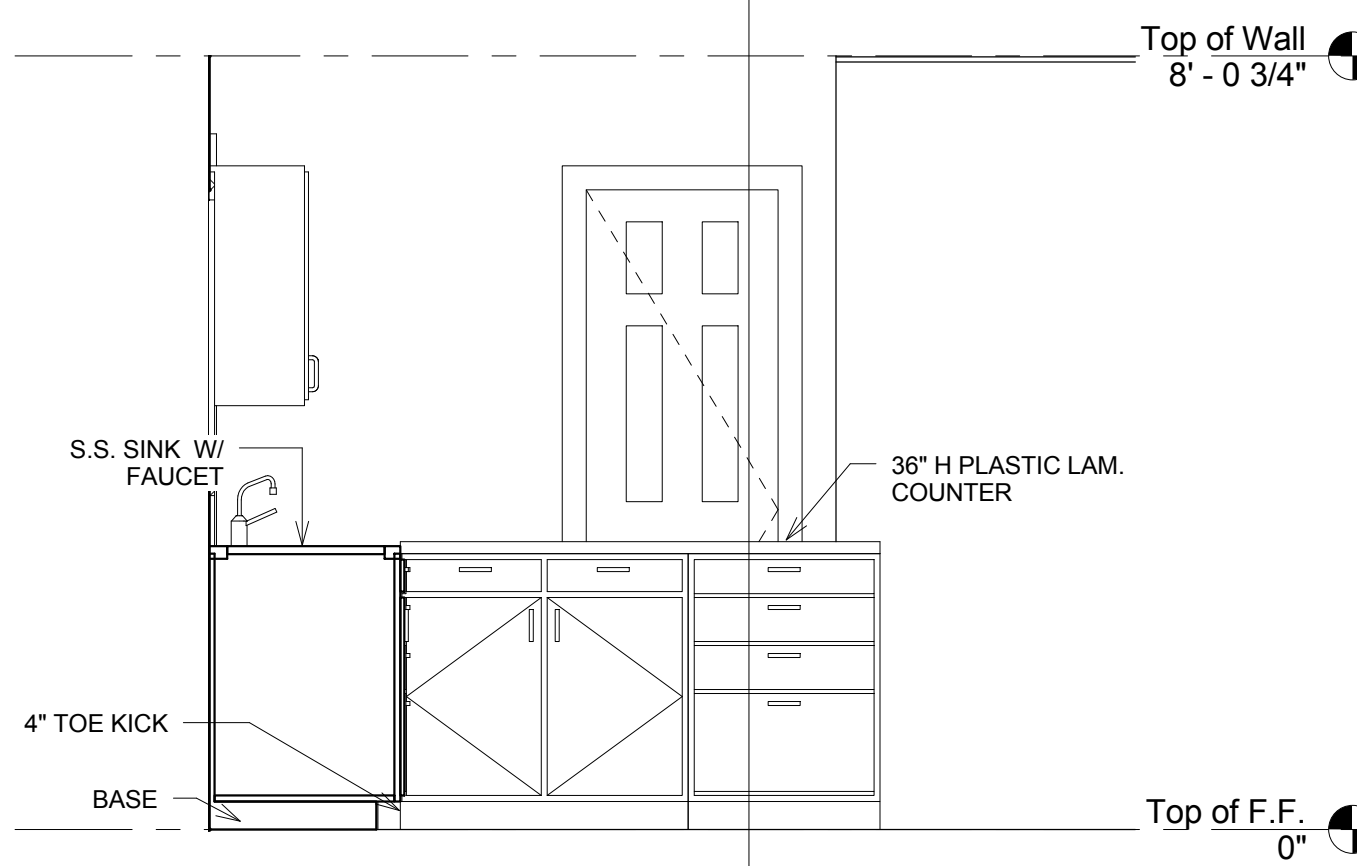

6 Elevation 1 - d
1/2" = 1'-0"

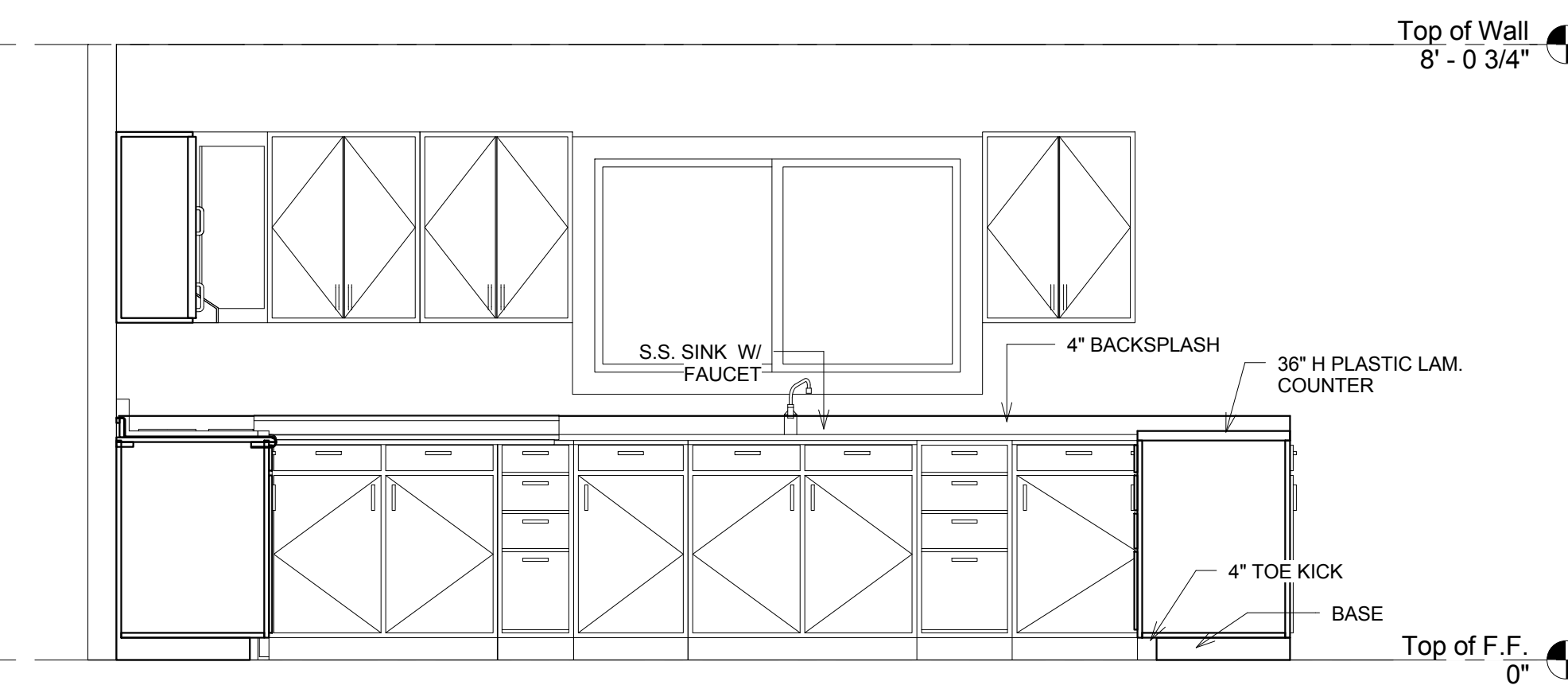

5 Elevation 1 - b
1/2" = 1'-0"

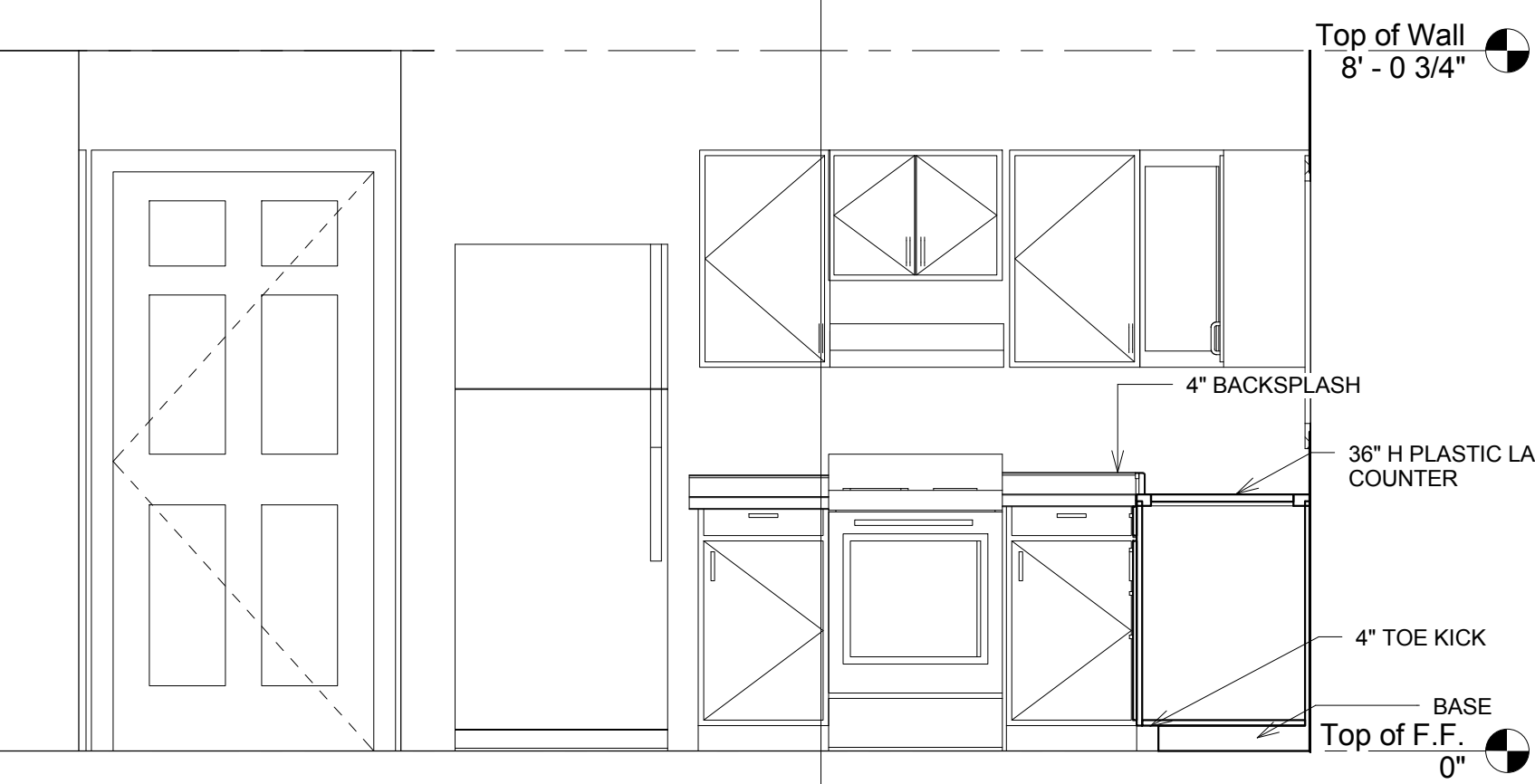

1 Elevation 1 - a
1/2" = 1'-0"

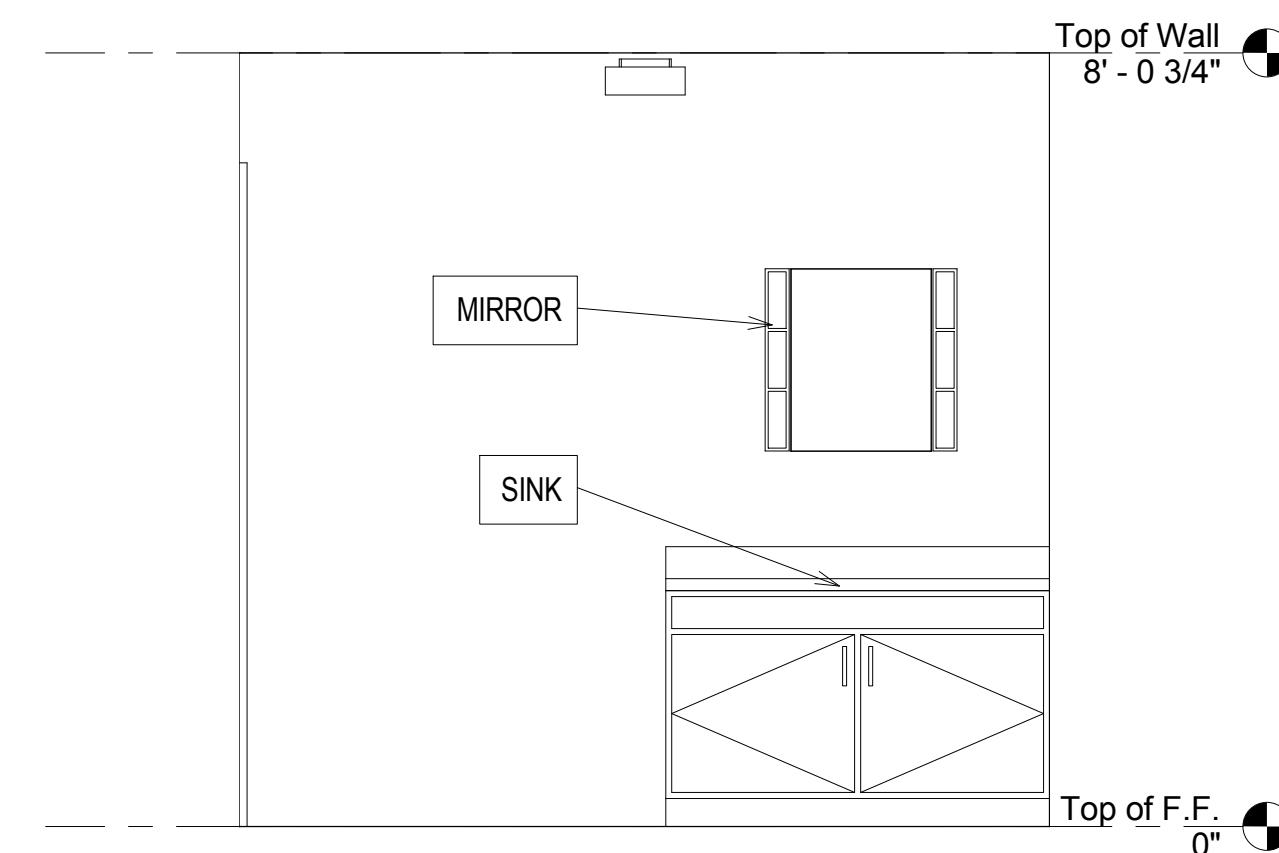

9 Elevation 2 - d
1/2" = 1'-0"

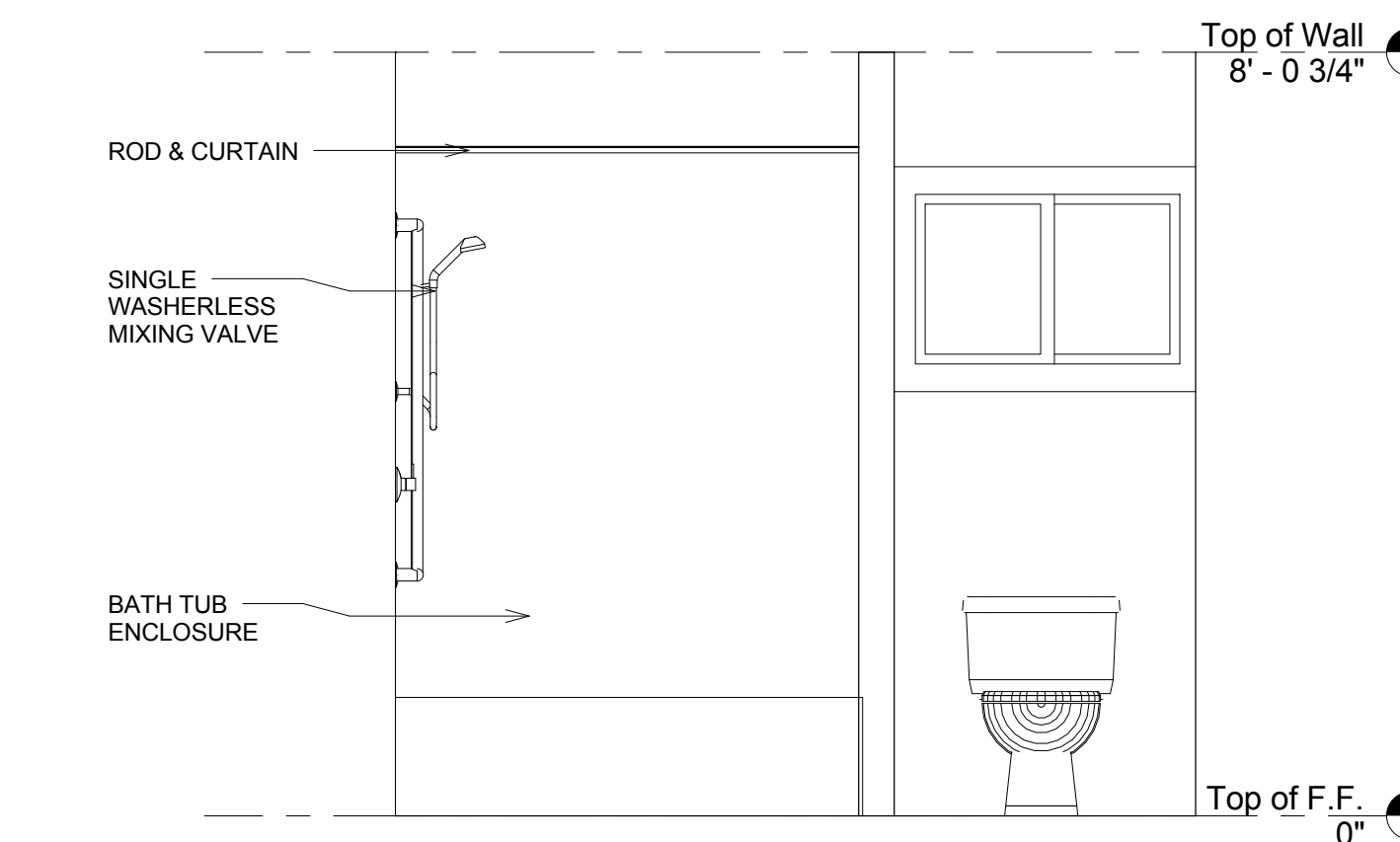

8 Elevation 2 - a
1/2" = 1'-0"

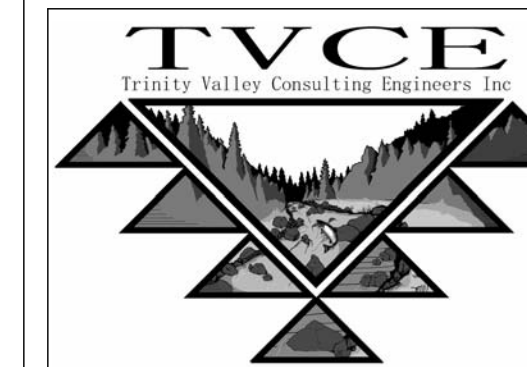

KARUK TRIBE
HOUSING AUTHORITY
Two Bedroom House

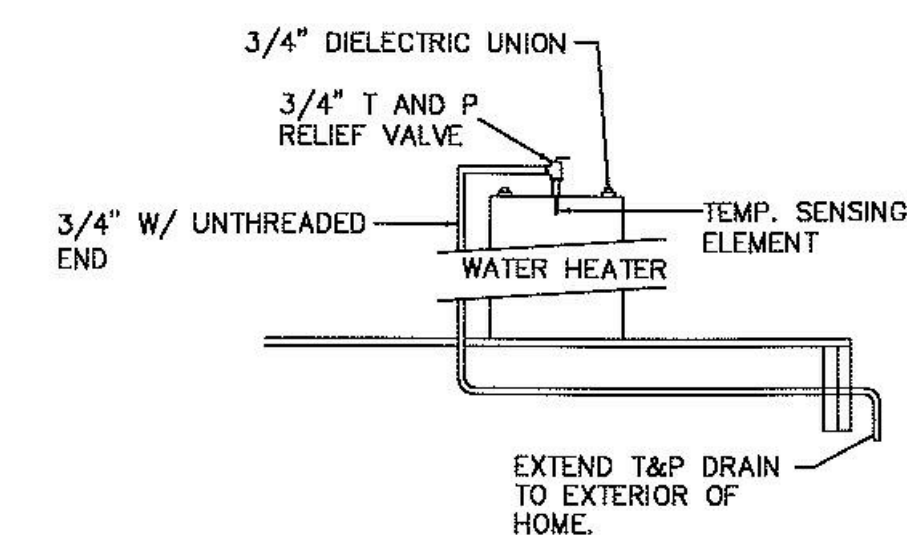
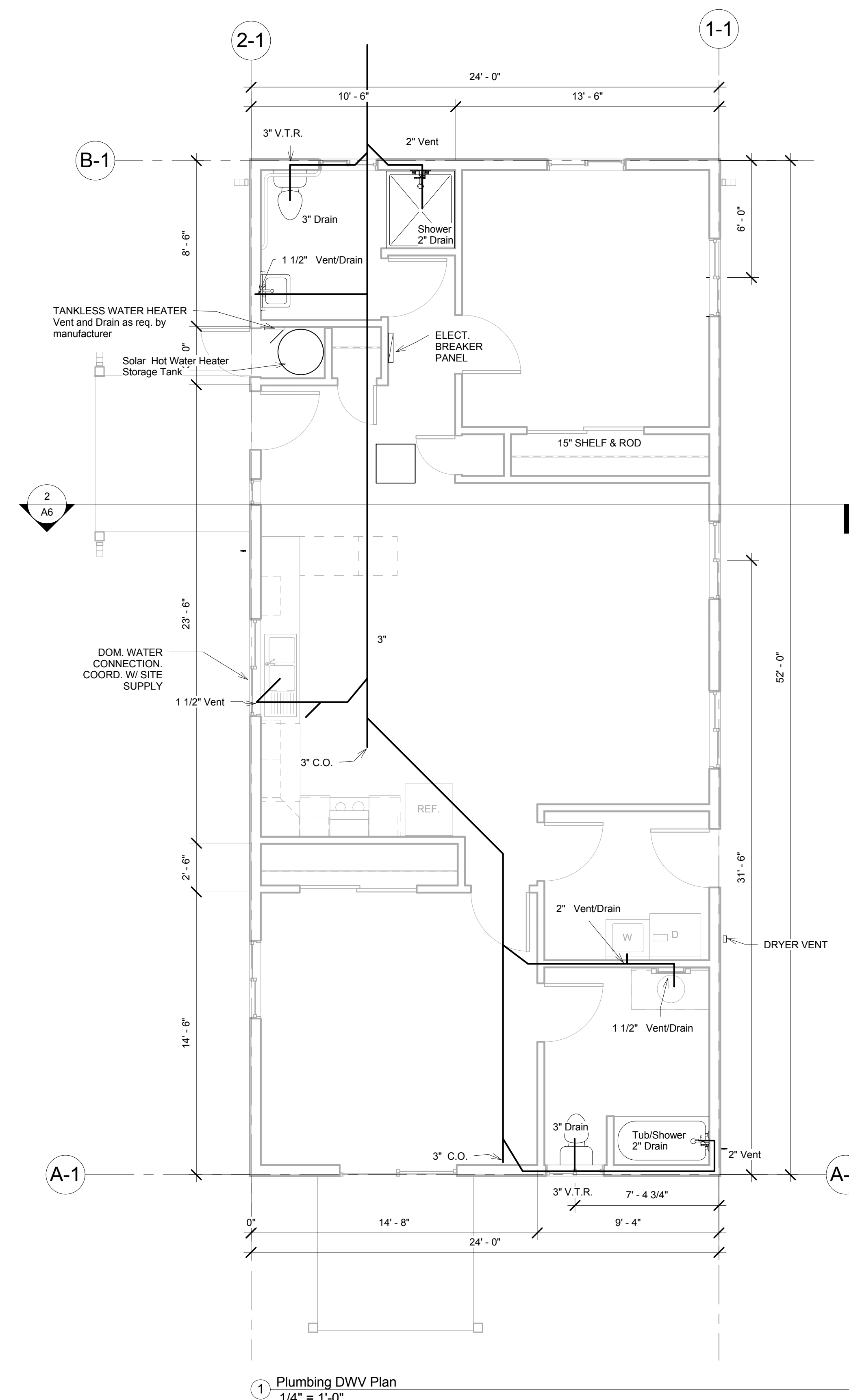
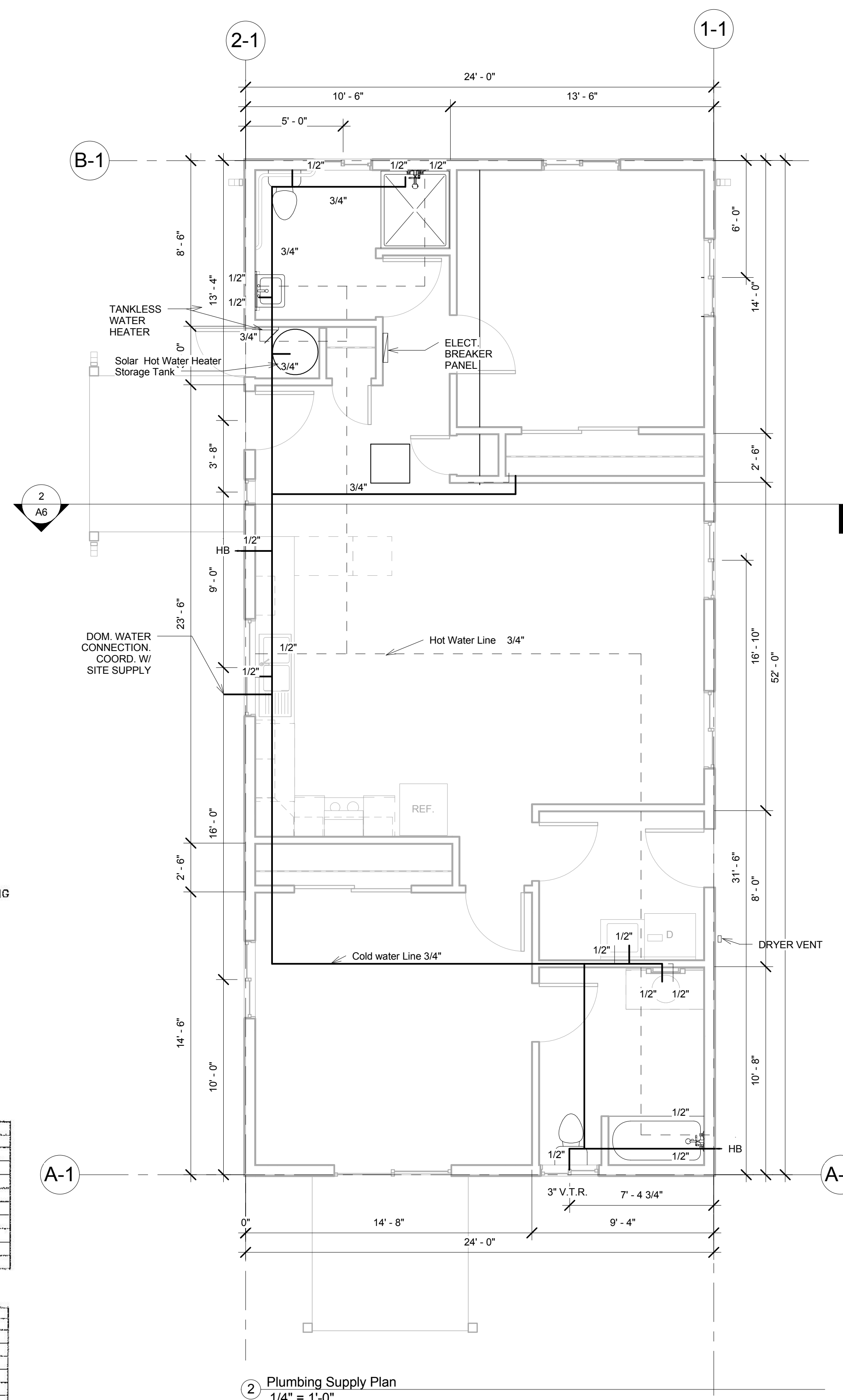

MINIMUM SIZE OF WATER METERS, MAINS AND DISTRIBUTION PIPING BASED ON WATER SUPPLY FIXTURE UNIT VALUES

Pressure Range—40 to 40 psi

METER AND SERVICE PIPE (inches)	DISTRIBUTION PIPE (inches)	MAXIMUM DEVELOPMENT LENGTH (ft)									
		40	60	80	100	150	200	250	300	400	500
1/2"	1/2"	3	2.5	2	1.5	1.5	1	1	.5	.5	.5
3/4"	3/4"	9.5	9.5	8.5	7	5.5	4.5	3.5	3	2.5	2
1"	1"	32	32	32	26	18	13.5	10.5	9	7.5	6
1 1/4"	1 1/4"	32	33	32	32	21	15	11.5	9.5	7.5	6.5
1 1/2"	1 1/2"	32	32	32	32	32	32	32	27	21	16.5
1 3/4"	1 3/4"	83	80	80	80	45	32	42	35	29	20
2"	2"	80	80	80	80	75	50	48	39	28	21
2 1/2"	2 1/2"	87	87	87	87	87	87	87	78	65	55
3"	3"	151	151	151	151	151	130	100	93	75	63

WATER-SUPPLY FIXTURE UNIT VALUES FOR VARIOUS PLUMBING FIXTURES AND FIXTURE GROUPS

TYPE OF FIXTURE OR GROUP OF FIXTURES	WATER-SUPPLY FIXTURE UNIT VALUE (u.e. x f.u.)		
	Hot	Cold	Combined
Bath tub (with/without overhead shower head)	1.0	1.0	1.4
Chorus washer	1.0	1.0	1.4
Dishwasher	1.4	—	1.4
Full-bath group with bathtub (with/without shower head) or shower stall	1.5	2.7	3.6
Half-bath group (water closet and lavatory)	0.5	2.5	2.6
House bibb (allstock)	—	2.5	2.5
Kitchen group (dishwasher and sink with/without garbage grinder)	1.9	1.0	2.5
Sink/shower	1.0	1.0	1.4
Laundry group (clothes washer and laundry tub)	1.6	1.0	2.5
Laundry tub	1.0	1.0	1.4
Lavatory	0.5	0.5	0.7
Showers stall	1.0	1.0	1.4
Water closet (tank type)	—	2.2	2.3

1 u.e. = 1 gallon per minute x 3.785 L/m.
2. The fixture unit value is assumed to be based on a flow demand of 2.5 gpm, which is for an individual fixture. If a large bathtub is required to handle a greater flow rate, the equivalent fixture unit value may be obtained from Table P200.1 or Table P200.2.

No.	Description	Date

Project number ktha 2015
Date 07/05/2015
Drawn by RKH
Checked by JMB

P1

Scale 1/4" = 1'-0"

NOTES
SEE ATTACHED SHEET P2 FOR PLUMBING NOTES AND DETAILS.
ALL PLUMBING MATERIALS AND INSTALLATIONS TO BE DONE PER NATIONAL, STATE AND LOCAL CODES
USE REMOVABLE TRAPS UNDER ALL SINKS TO PROVIDE CLEANOUT ACCESS
A TEMPERATURE-LIMITING DEVICE CONFORMING TO ASSE 1070 IS REQUIRED AT WHIRLPOOL TUBS AND BATH TUBS TO LIMIT WATER TEMPERATURE TO 120 DEGREES F

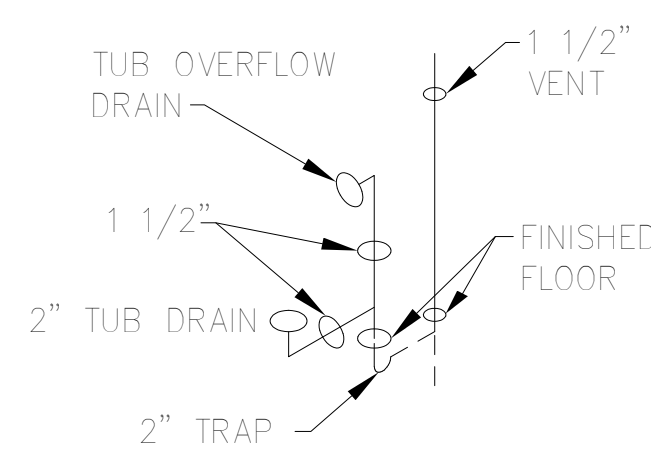

TUB/SHOWER

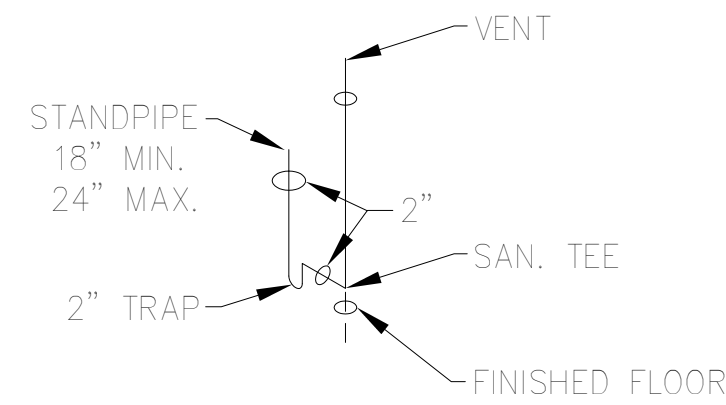

CLOTHES WASHER

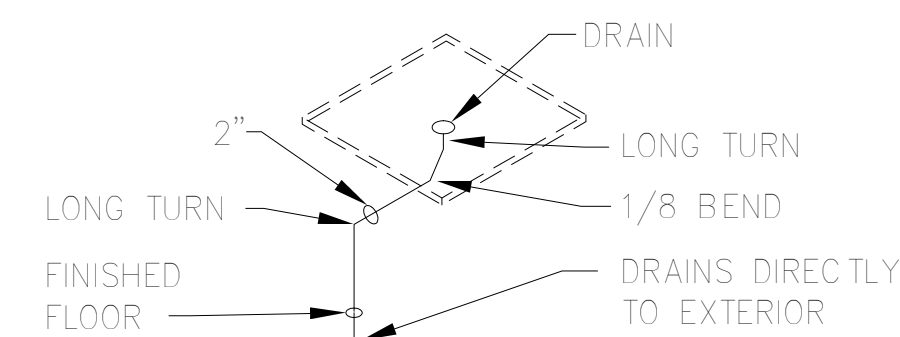

WASHER/WATER HEATER PAN USED WHEN CRAWL SPACE OR USED WHEN EITHER IS INSTALLED ON 2ND FLOOR

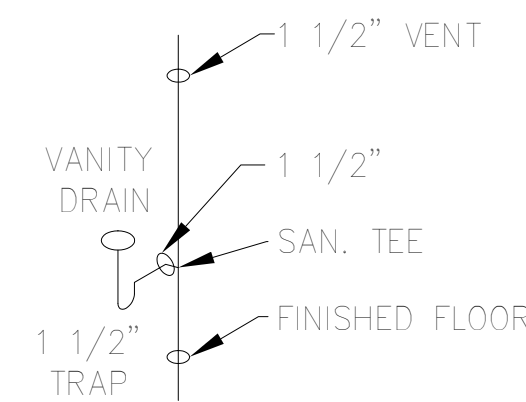

BATHROOM VANITY

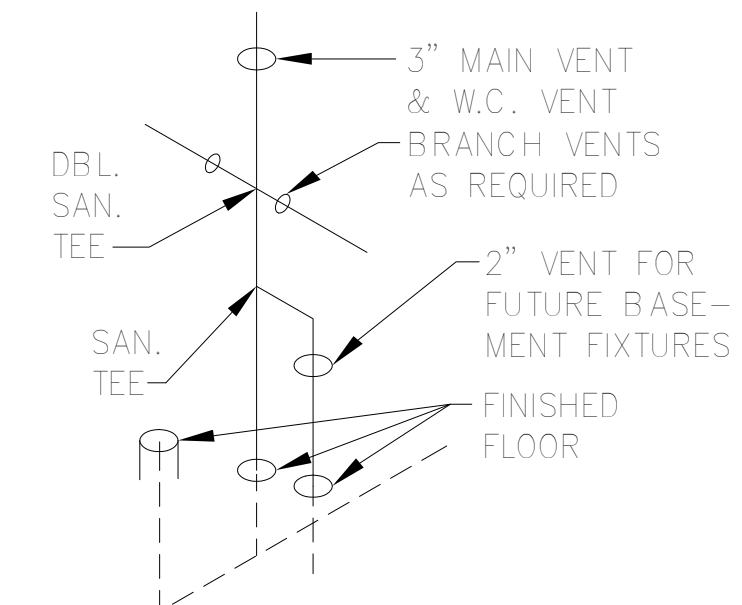

WATER CLOSET AND MAIN VENT

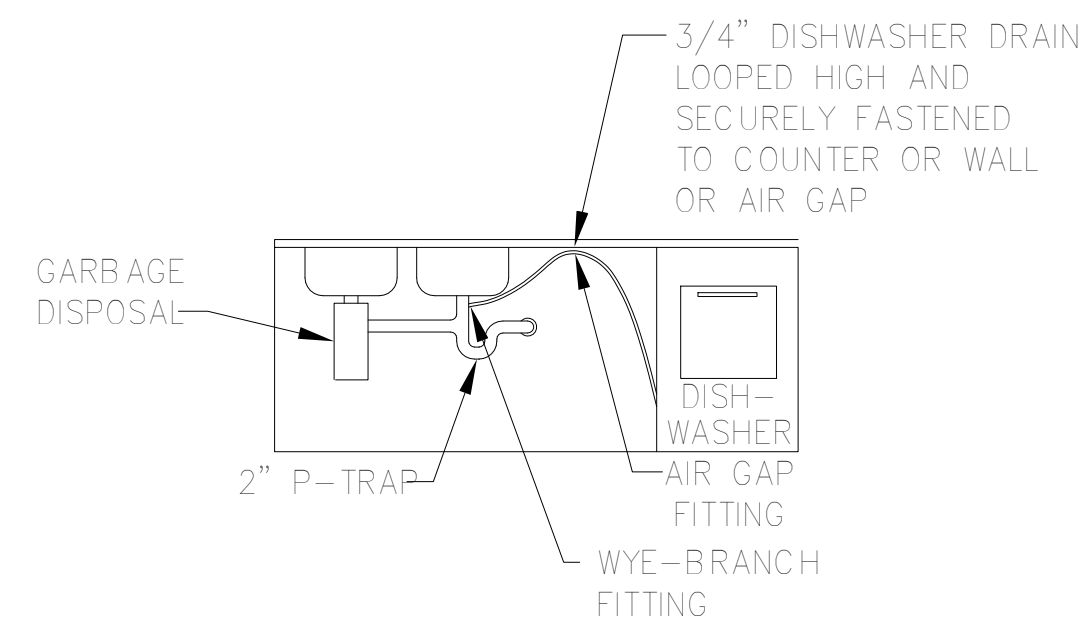

KITCHEN SINK/DISHWASHER/DISPOSAL

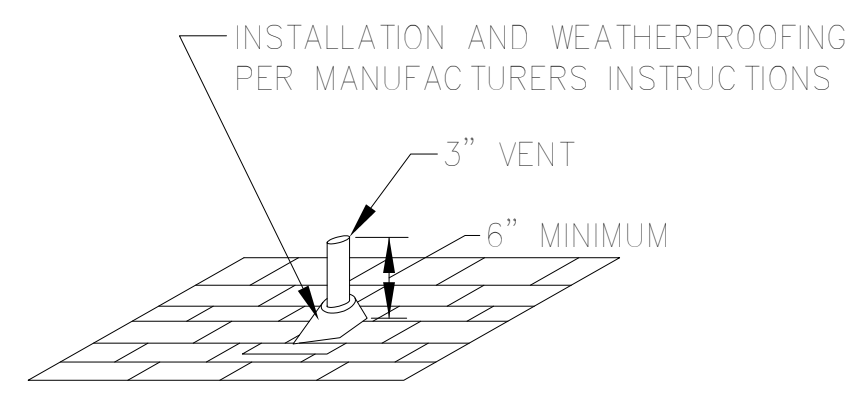

VENT THRU ROOF DETAIL

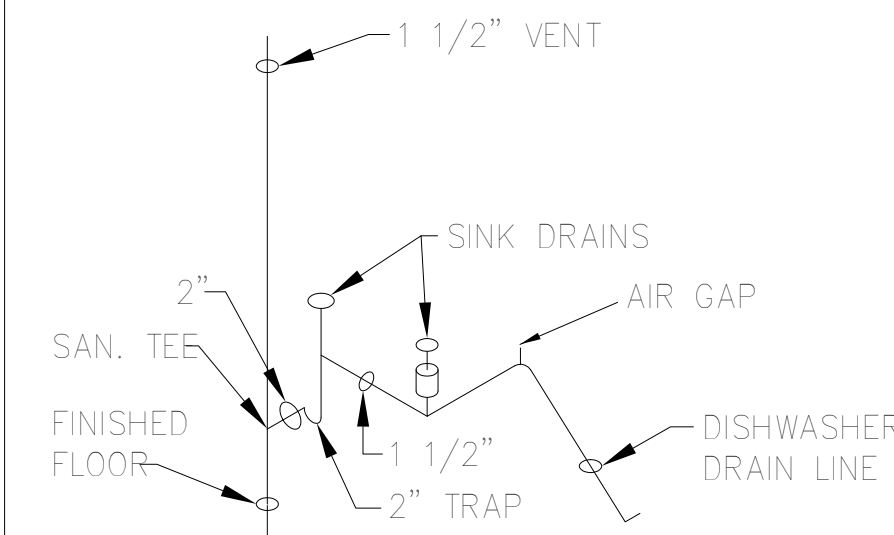

KITCHEN SINK/DISHWASHER DETAIL

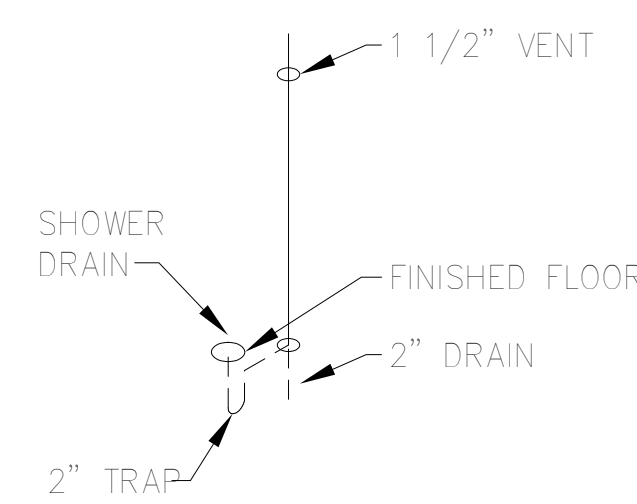

SHOWER

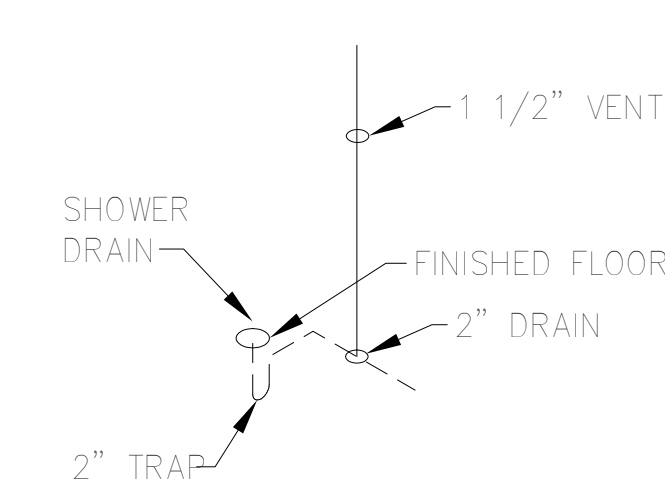

SHOWER

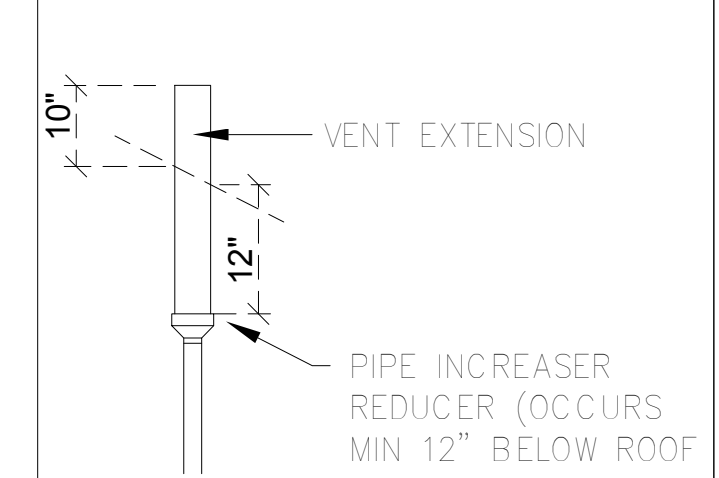

FROST CLOSURE

DWV NOTES:

- ALL WASTE AND VENT LINES ARE TO BE ABS OR PVC PIPE PROVIDED DWELLING DOES NOT EXCEED TWO STORIES IN HEIGHT. SUPPLY LINES ARE TO BE COPPER.
- PITCH ON HORIZONTAL WASTE LINES SHALL BE 1/4", IF A SPECIAL CONSTRUCTION CONDITION EXISTS, LOCAL AUTHORITIES MAY GIVE APPROVAL FOR 1/8" SLOPE ON PIPE DIAMETERS OF 4" OR GREATER.
- WASTE LINES: INSTALL WYE W/ CLEANOUT PRIOR TO EXITING WALL FOR CONNECTION TO DISPOSAL SYSTEM.
- PVC-DWV PIPE SUPPORTS: AT BRANCHES, CHANGES IN DIRECTION AND AT THE BASE, EACH FLOOR AND MID STORY (VERTICAL) MAXIMUM EVERY 3'-0" AT THE END OF BRANCHES, AND CHANGE OF DIRECTION OR ELEVATION, 4" MINIMUM MAIN WASTE TO SEPTIC (BY BUILDER).
- PLASTIC PIPE SHALL NOT PENETRATE FIRE RATED ASSEMBLIES INCLUDING FLOOR/CEILING. PIPING SHALL BE FIRESTOPPED WHERE REQUIRED WITH MATERIAL EQUIVALENT TO CONSTRUCTION WHICH IT PENETRATES & BE SUITABLE TO PIPE MATERIAL OR USE METAL PIPE FROM A MIN. OF ABOVE ASSEMBLY & DOWN.
- EACH DWELLING SHALL HAVE ONE MAIN 3 INCH MIN. STACK FROM BUILDING DRAIN AND AT A MIN. OF 6" ABOVE THE ROOF LINE
- ALL TRAP ARMS MUST BE SUPPORTED WITH 3/4" MINIMUM BEARING.
- ALL PLASTIC PIPE MUST BE SUPPORTED AT INTERVALS IN ACCORDANCE WITH APPLICABLE PLUMBING CODES
- HORIZONTAL TO HORIZONTAL & VERTICAL TO HORIZONTAL DRAIN CHANGES IN DIRECTION SHALL BE 45 DEGREE WYES, LONG SWEEP 90 DEGREE ELBOWS, LONG SWEEP TYS, 6TH., 8TH. OR 16TH BENDS, APPROVED COMBINATIONS OF THESE OR EQUIVALENT LONG SWEEP FITTINGS. SHORT SWEEPS PERMITTED IN SINGLE BRANCH HORIZONTAL TO VERTICAL CHANGES IN DIRECTION ON 3 INCH OR LARGER.
- TRAPS SHALL BE PLACED AS CLOSE AS POSSIBLE TO FIXTURE OUTLET. MAXIMUM VERTICAL DROP FROM FIXTURE OUTLET TO TRAP WEIR IS 24"
- INACCESSIBLE TRAPS SHALL NOT HAVE UNIONS, CLEANOUTS OR SLIPJOINTS. ACCESSIBLE TRAPS SHALL BE REMOVABLE WITH UNION IN TRAP SEAL OR HAVE CLEANOUT OPENING SAME SIZE AS TRAP.
- ALL HORIZONTAL VENT BRANCH PIPING SHALL BE LOCATED A MINIMUM OF 6" ABOVE THE FLOOR LEVEL OF THE HIGHEST FIXTURE IN THAT BRANCH.
- MAXIMUM DISTANCE OF FIXTURE TRAP WEIR TO VENT SHALL BE IN ACCORDANCE WITH ALL APPLICABLE PLUMBING CODES.
- PLASTIC PIPING SHALL BE PROTECTED WITH 1/16" (15 GAUGE) STEEL PLATE WHEN PIPE PASSES THRU WOOD MEMBERS LESS THAN 1 1/4 INCHES FROM EDGE OF MEMBER. CPC2001 313.9
- FALL IN TRAP NOT ACCEPTABLE IN CPC
- THE VENT PIPE OPENING FROM A SOIL OR WASTE PIPE, EXCEPT FOR WATER CLOSET AND SIMILAR FIXTURES, SHALL NOT BE BELOW THE WEIR OF THE TRAP. CPC2001 1002.4

ISLAND VENT

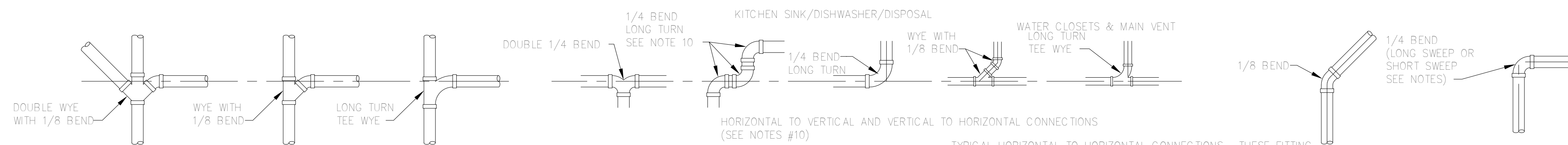
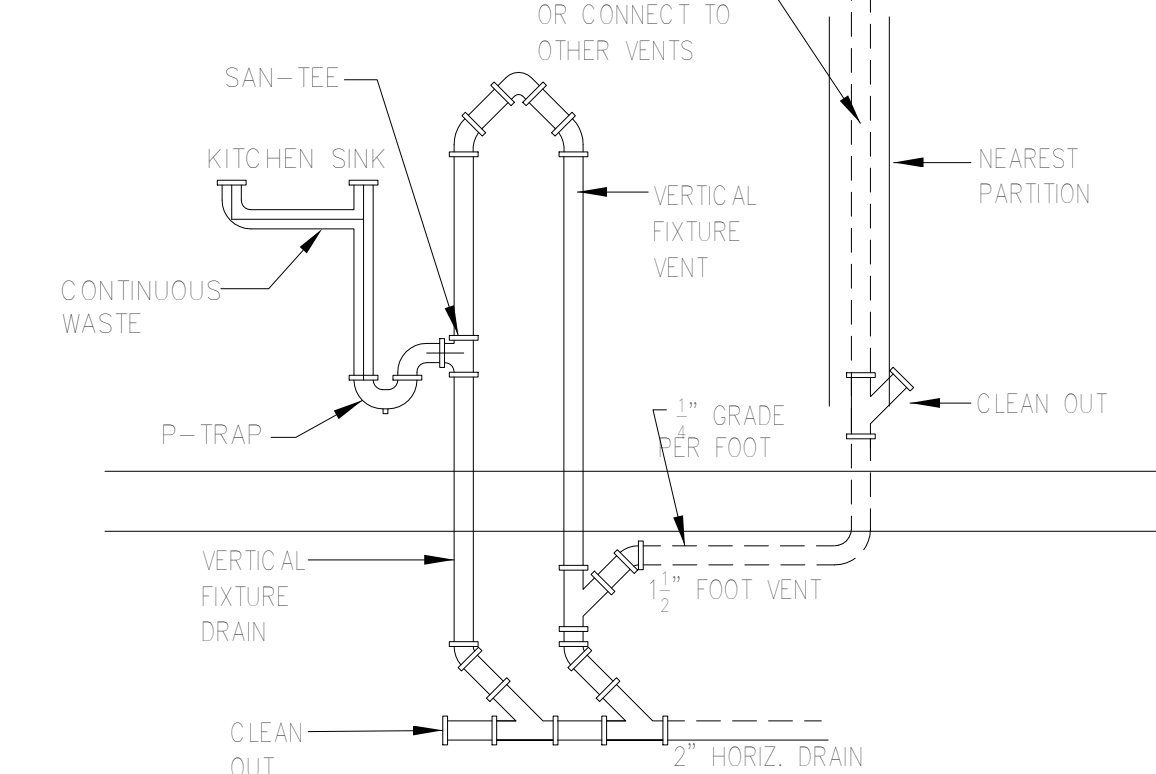

TYPICAL HORIZONTAL TO HORIZONTAL CONNECTIONS. THESE FITTING WILL BE USED TOGETHER OR INDIVIDUALLY TO DRAIN FIXTURES IN COMPLIANCE WITH STATE CODES (SEE NOTE #10)

- FIRST FLOOR FIXTURES SHALL CONNECT INTO HORIZONTAL BUILDING DRAIN MORE THAN 10 PIPE DIAMETERS DOWNSTREAM (TAKE THE DIAMETER OF THE CONNECTION TIMES 10 AND THAT IS THE MIN. DISTANCE YOU MUST BE TO THE STACK BASE & NOT CONNECT INTO SECOND FLOOR DRAIN STACK.
- POTABLE WATER SYSTEM SHALL BE DISINFECTED ON SITE BY SITE BUILDER IN ACCORDANCE WITH APPLICABLE STATE PLUMBING CODES
- BACKFLOW DEVICES, VACUUM BREAKERS & AIR GAPS: FOR WATER DISTRIBUTION SYSTEMS "PROTECTION OF POTABLE WATER SUPPLY."
A.- WATER HEATER LOCATED @ OR ON LIVING SPACE LEVEL MUST HAVE A BACKFLOW DEVICE INSTALLED AND MUST HAVE A WATERTIGHT PAN OF CORRISON RESISTANT MATERIALS INSTALLED.
B.- CLOTHES WASHER (IF NOT BUILT IN TO THE APPLIANCE) MUST HAVE AN BACKFLOW DEVICE INSTALLED.
- WASHER HEATER AND FURNACE SHALL BE BRACED TO SECURE AGAINST SEISMIC MOVEMENTS. USE PLUMBER TAPE BRACING OR OTHER APPROVED FASTENERS.

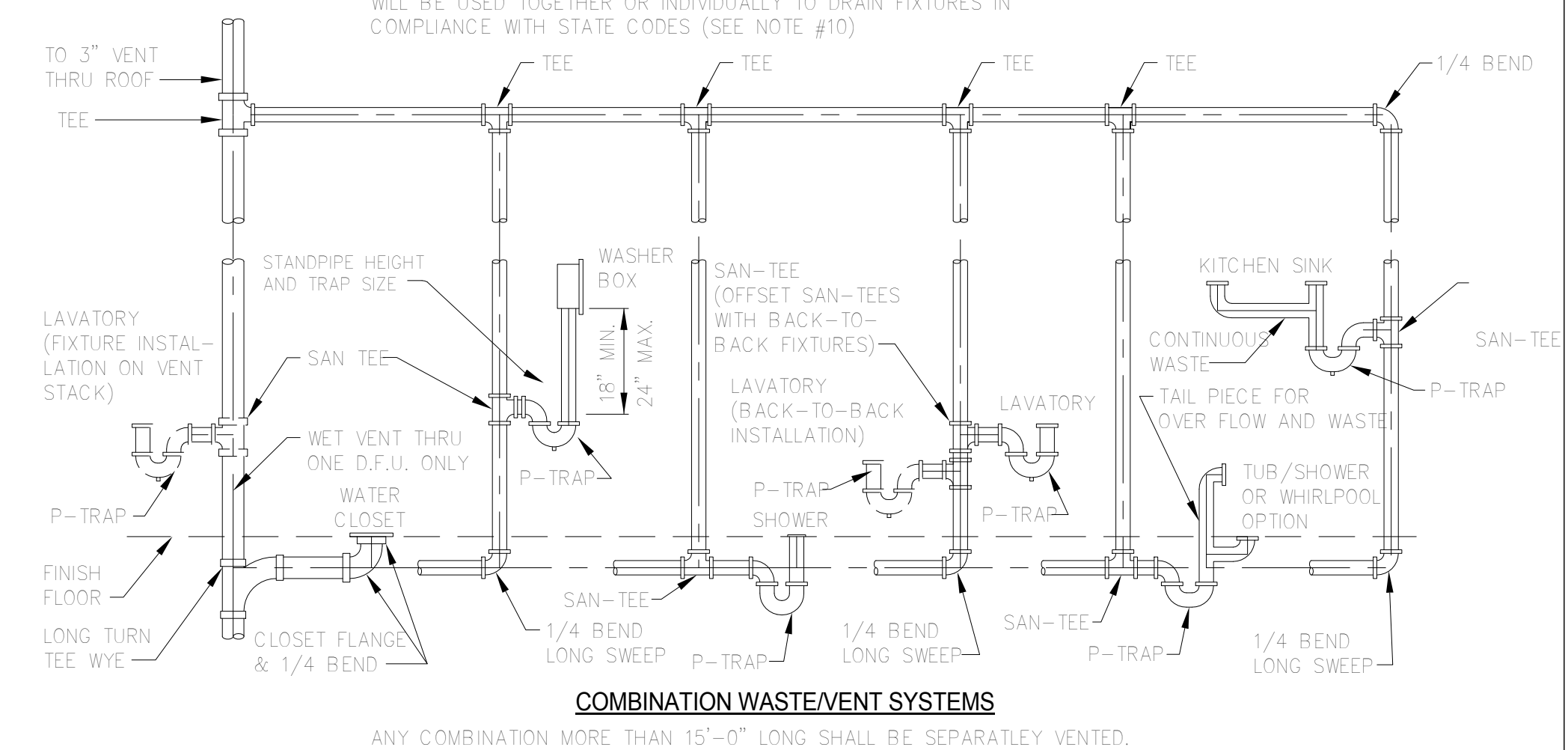

COMBINATION WASTE/VENT SYSTEMS

ANY COMBINATION MORE THAN 15'-0" LONG SHALL BE SEPARATELY VENTED.

JMB ARCHITECTURE
ARCHITECTURE PLANNING
 4767 HIGHWAY 96 PO BOX 1170
 WILLOW CREEK, CA 95573
 707.629.0010 fax 707.629.2348
 email: jmbarchitect@snowcrest.net

TVCE
 Trinity Valley Consulting Engineers Inc.
 167 Walnut Way PO BOX 1567
 WILLOW CREEK, CA 95573
 707.629.3000 fax 707.629.3011
 email: tvce@tvce.biz

Electrical Consultant Pace Engineering
 Address 1730 South Street Redding, CA 96001
 Phone 530 244-0202
 Fax 530 244
 e-mail
 Bldg. Energy Consultant Address 1125 16th Street, Ste. 216 Arcata, CA 95521
 Phone 707 826-1433
 Fax 707-826-1430
 e-mail ann@abbaytechnicalservices.com

KARUK TRIBE HOUSING AUTHORITY
Two Bedroom House

No.	Description	Date

Plumbing Notes and Details

Project number	ktha 2015
Date	07/05/2015
Drawn by	RKH
Checked by	JMB

P2
 Scale 3/8" = 1'-0"

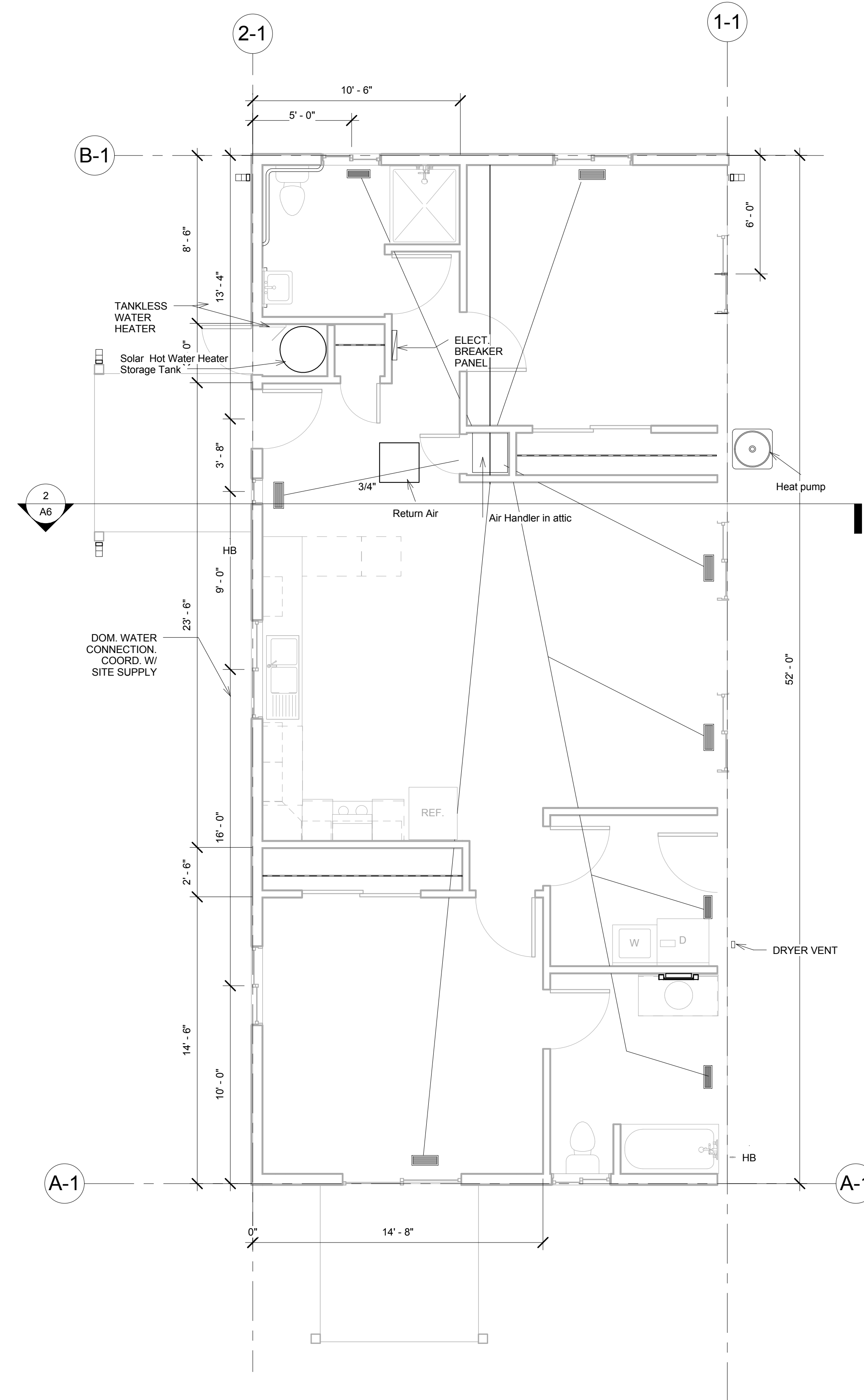

1 Mechanical Plan
1/4" = 1'-0"

DISCLAIMER:
HEATING PLANS ARE SHOWN FOR REPRESENTATION ONLY.
HEATING AND COOLING SYSTEMS WILL BE DESIGNED AND INSTALLED BY THE HEATING SYSTEM SUPPLIER
AND WILL BE REVIEWED AND APPROVED BY LOCAL JURISDICTIONS HAVING AUTHORITY

- NOTES:
1. UNIT TO BE BRYANT OR EQUAL WITH THE AIR HANDLER IN THE ATTIC AND HEAT PUMP OUTSIDE ON GROUND.
 2. FLEX DUCTING
 3. ALL AIR DISTRIBUTION SYSTEMS, DUCTS, PLENUMS AND OTHER EQUIPMENT SHALL BE DESIGNED AND INSTALLED IN ACCORDANCE WITH CMC AND UL 181 STANDARDS.
 4. BUILDING HEATING AND COOLING LOADS SHALL BE DETERMINED USING THE ASHRAE OR SMACNA STANDARDS.
 5. ALL DUCT SEAL AND INSULATION SHALL MEET THE CENC REQUIREMENTS.
 6. ALL METAL DUCTS FOR STATIC AIR PRESSURE SHALL COMPLY WITH TABLE 6-1 2001 CMC

JMB
ARCHITECTURE
ARCHITECTURE
PLANNING
4767 HIGHWAY 96 PO BOX 1170
WILLOW CREEK, CA 95573
707.629.0010 fax 707.629.2348
email: jmbarchitect@snowcrest.net

TVCE
Timber Valley Consulting Engineers, Inc.
67 Walnut Way PO BOX 1567
WILLOW CREEK, CA 95573
707.629.3000 fax 707.629.3011
email: tvce@tvce.biz

Electrical Consultant Pace Engineering
Address 1730 South Street Redding, CA 96001
Phone 530 244-0202
Fax 530 244
e-mail
Bldg. Energy Consultant Abbey Technical Services
Address Anny McQuerry 1125 16th Street, Ste. 216 Arcata, CA 95521
Phone 707 826.1433
Fax 707-826-1430
e-mail anny@abbaytechnicalservices.com

KARUK TRIBE
HOUSING AUTHORITY
Two Bedroom House

No.	Description	Date

Mechanical Plan	
Project number	ktha 2015
Date	07/05/2015
Drawn by	RKH
Checked by	JMB
M1	
Scale	1/4" = 1'-0"

GENERAL NOTES

- UNLESS OTHERWISE INDICATED, RECEPTACLES AND JUNCTION BOXES SHALL BE CONNECTED TO THE CIRCUIT INDICATED USING 1/2" C-2#12,1#12G. RECEPTACLE CIRCUITS SHALL BE CONCEALED IN WALLS OR ABOVE CEILINGS.
- MAINTAIN A MINIMUM 30"W x 36"D CLEAR SPACE IN FRONT OF ALL ELECTRICAL DISCONNECTS AND PANELS PER THE CEC.
- MAINTAIN WORKING SPACE AND 6'-6" HEAD ROOM IN FRONT OF ALL ELECTRICAL EQUIPMENT IN ACCORDANCE WITH CEC.
- CONDUCTORS SHALL BE NON-METAL SHEATHED CABLE (ROMEX) UNLESS OTHERWISE SHOWN.
- RECEPTACLES SHALL BE SPECIFICATION GRADE WITH NUMBER OF POLES AS REQUIRED. RECEPTACLES SHALL BE PROVIDED WITH GROUND TERMINALS AND SCREW TERMINALS SUITABLE FOR NO. 10 CONDUCTORS. RECEPTACLES SHALL BE WHITE AND RATED FOR 15A, 120V WITH A NEMA 5-15R CONFIGURATION. DEVICE PLATE SHALL BE PLASTIC WITH COLOR TO MATCH RECEPTACLES.
- PANELBOARDS SHALL BE RATED AS SHOWN AND PROVIDED WITH TIN-PLATED ALUMINUM BUS, THERMAL MAGNETIC CIRCUIT BREAKERS AS SHOWN, AND NEMA 1 ENCLOSURE UNLESS OTHERWISE INDICATED.

KEY NOTES

- PROVIDE AND INSTALL RECEPTACLE 6" ABOVE COUNTER HEIGHT.
- SWITCHED GARBAGE DISPOSAL RECEPT.
- A-19 INCANDESCENT LIGHT FIXTURE TO BE DETERMINED.
- 2 TUBE, F32W T8 SURFACE MOUNT FLUORESCENT FIXTURE.
- WALL SCONCE LIGHT FIXTURE TO BE DETERMINED.
- ARC FAULT RECEPT.
- PROVIDE AND INSTALL IN ACCORDANCE WITH UTILITY REQUIREMENTS.
- PROVIDE RECEPTACLES TO MATCH EQUIPMENT CONFIGURATION.
- PROVIDE AND INSTALL SMOKE DETECTOR IN LOCATION SHOWN.
- PROVIDE AND INSTALL RECEPTACLE 48" ABOVE FINISHED FLOOR.

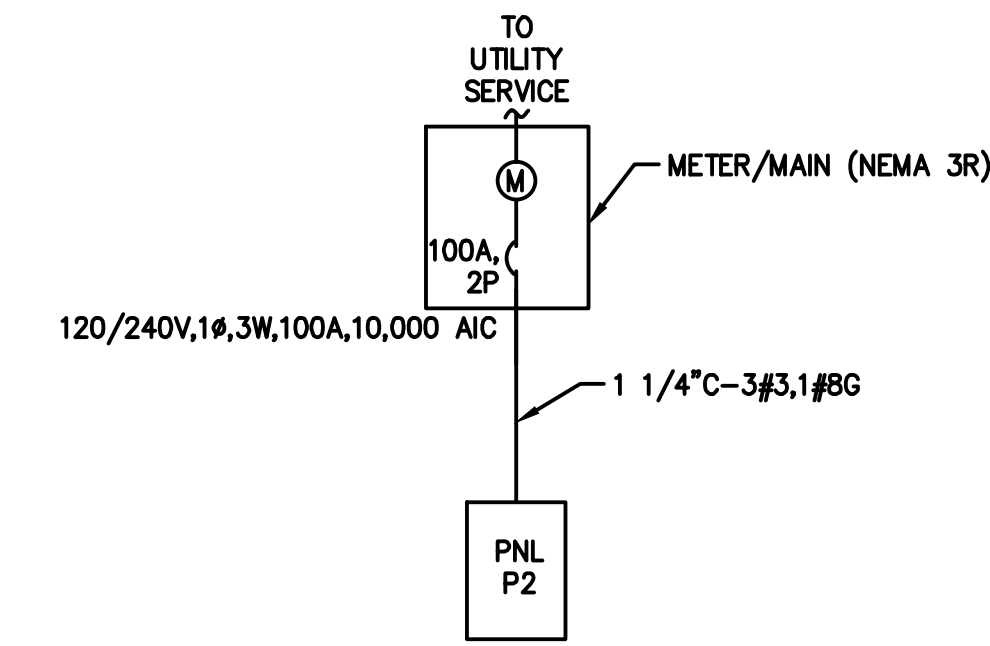

ONE-LINE DIAGRAM

100A BUS		CIRCUIT AMPS	
MLO		MLO	
BEDROOM 2 RECEPT	20	1	20
LAUNDRY RM RECEPT	20	3	20
DRYER	30	5	20
REFRIG	20	7	20
GARBAGE DISPOSAL	50	10	20
OVEN	30	13	20
BEDROOM 1 RECEPT	20	15	20
BEDROOM 1&2 LTG	20	17	20
GREAT RM/CLOSET LTG	20	19	20
SPARE	20	21	20
SPARE	20	23	20
SPARE	20	25	20
SPARE	20	27	20
SPARE	20	29	20
		30	20
		31	20
		32	20
		33	20
		34	20
		35	20
		36	20
		37	20
		38	20
		39	20
		40	20
		41	20
		42	20
		43	20
		44	20
		45	20
		46	20
		47	20
		48	20
		49	20
		50	20
		51	20
		52	20
		53	20
		54	20
		55	20
		56	20
		57	20
		58	20
		59	20
		60	20
		61	20
		62	20
		63	20
		64	20
		65	20
		66	20
		67	20
		68	20
		69	20
		70	20
		71	20
		72	20
		73	20
		74	20
		75	20
		76	20
		77	20
		78	20
		79	20
		80	20
		81	20
		82	20
		83	20
		84	20
		85	20
		86	20
		87	20
		88	20
		89	20
		90	20
		91	20
		92	20
		93	20
		94	20
		95	20
		96	20
		97	20
		98	20
		99	20
		100	20

PANEL P2
VOLTAGE: 120/240V
LOCATION: LAUNDRY RM
MOUNTING: SURFACE
AMPS IC: 10,000

ELECTRICAL SYMBOLS

- CONDUIT EXPOSED
- CONDUIT CONCEALED OR BURIED
- CROSSHATCHES ON CONDUIT RUN INDICATES NUMBER OF #12 CONDUCTORS
- SUBSCRIPT G INDICATES GREEN GROUND CONDUCTOR
- LA-2 HOME RUN-DESTINATION SHOWN
- SURFACE MOUNT PANELBOARD
- LUMINAIRE
- LUMINAIRE
- WALL MOUNTED LUMINAIRE
- SMALL LETTER SUBSCRIPT AT SWITCH AND LUMINAIRE INDICATES SWITCHING
- TYPE INDICATED SEE LUMINAIRE AND DEVICE SCHEDULE
- CONVENIENCE RECEPTACLE (DUPLICATE UNLESS SPECIFIED OTHERWISE)
- WP-WEATHERPROOF
- AFCI-ARCH FLASH
- 4-PLEX CONVENIENCE RECEPTACLE
- CURRENT INTERRUPTER
- GROUND FAULT INTERRUPTER
- MOUNT 15" AFF FROM THE BOTTOM OF THE RECEPT UNLESS OTHERWISE NOTED.
- TELEPHONE/DATA RECEPTACLE (OUTLET BOX ONLY)
- WALL SWITCH: MOUNT SWITCHES 48" AFF TO TOP OF DEVICE UNLESS OTHERWISE INDICATED. TYPE INDICATED SEE LUMINAIRE AND DEVICE SCHEDULE.
- 3-THREE WAY
- CIRCUIT BREAKER, THERMAL MAGNETIC TRIP SHOWN, 3-POLE UNLESS INDICATED OTHERWISE

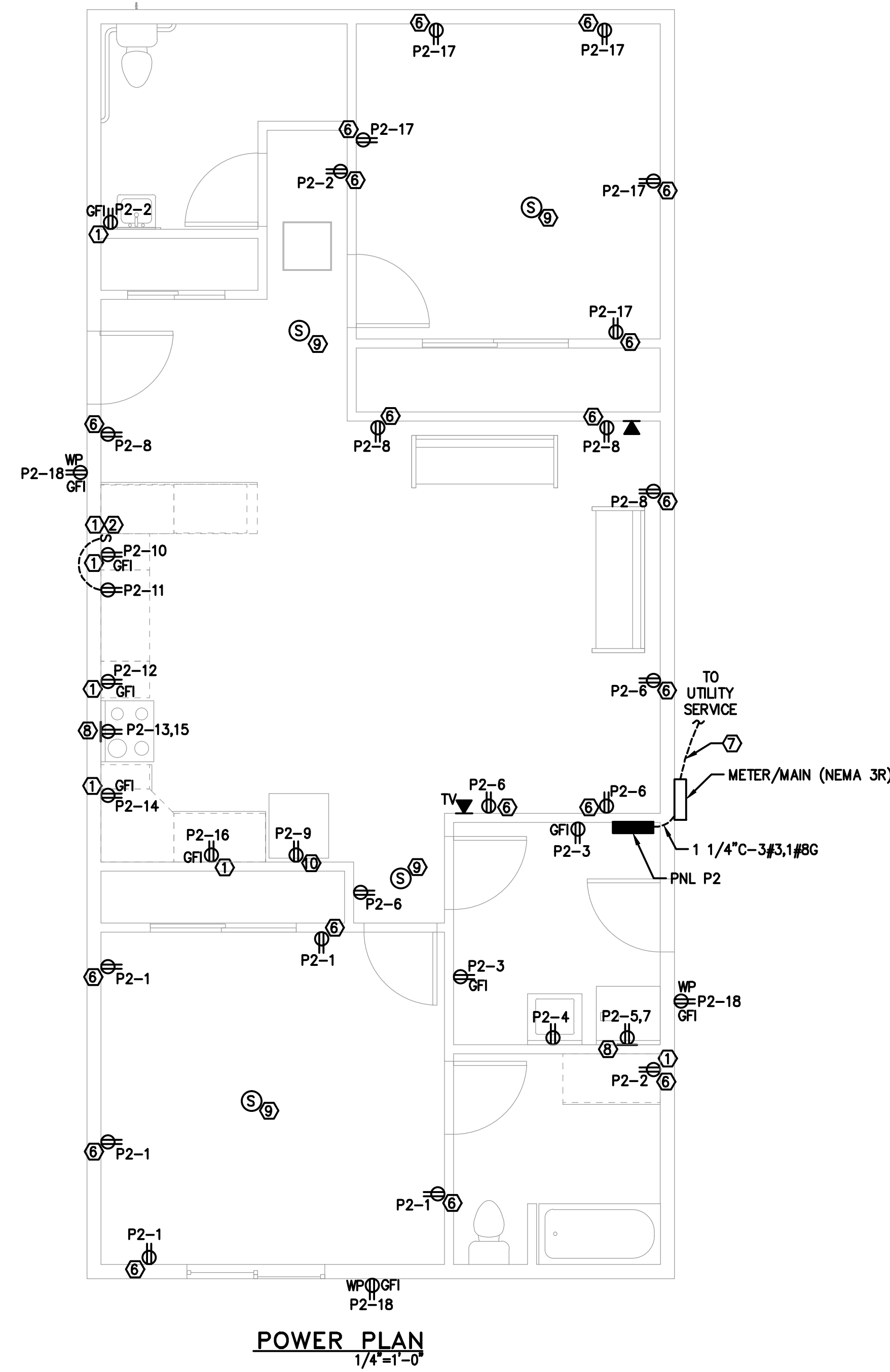

POWER PLAN
1/4"=1'-0"

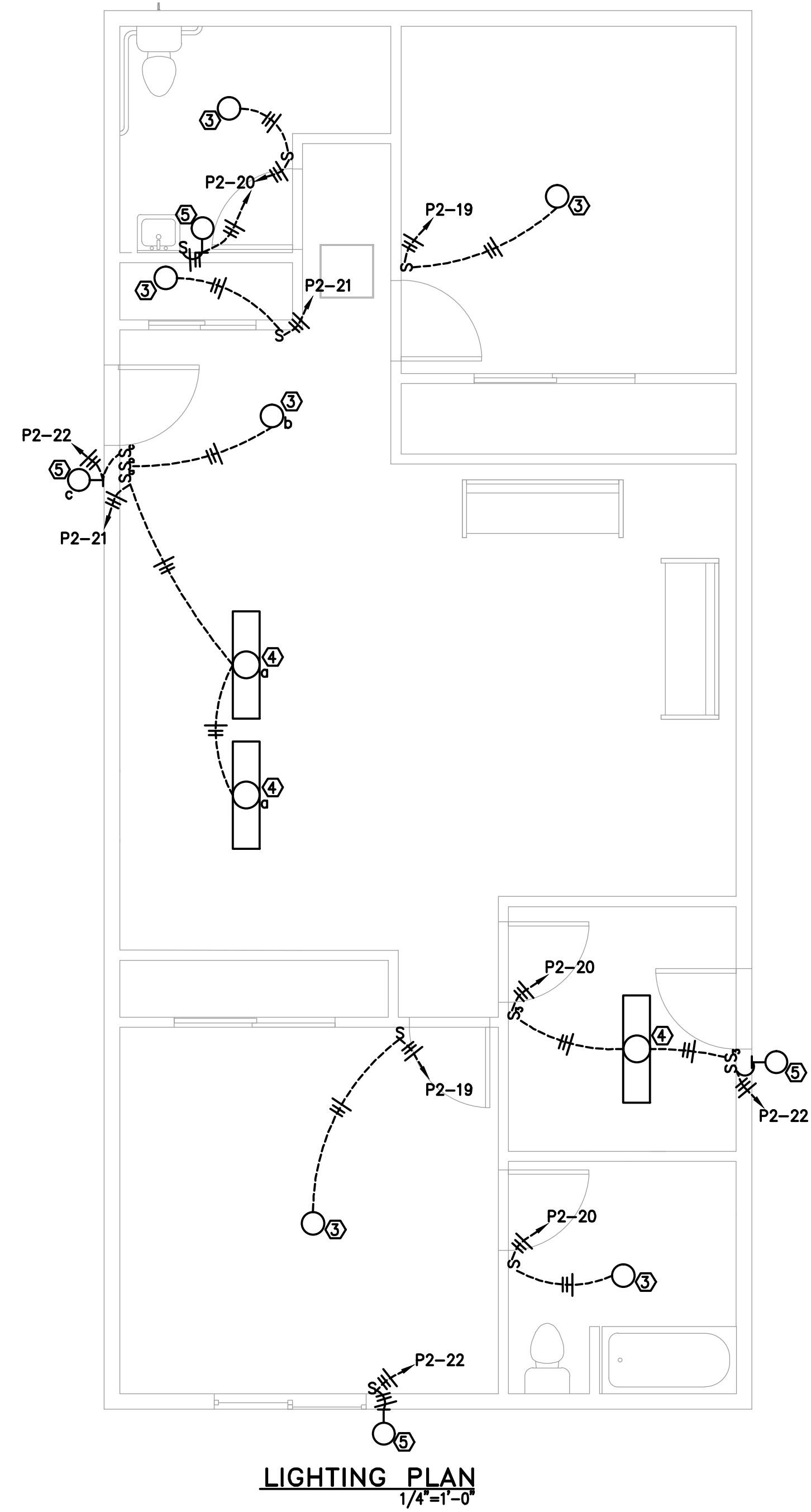

LIGHTING PLAN
1/4"=1'-0"

PACE ENGINEERING
REDDING, CALIFORNIA

DES CA	CKD CA	JOB NO.
DRN JS	DATE 08/05/15	2274.17

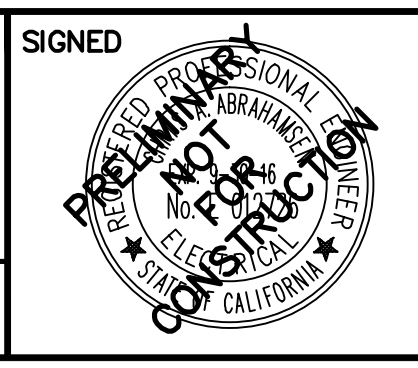

SIGNED

KARUK TRIBE HOUSING AUTHORITY
635 JACOBSON WAY
HAPPY CAMP, CA 96039
TWO BEDROOM FLOOR PLAN

SHEET
E2.2

Plot Date: August 06, 2015 2:28 PM
File Name: M:\Land Projects\227417 KTHA\DWG\E22.dwg Layout: E22